

**MATH 120A COMPLEX VARIABLES NOTES: REVISED**  
**December 3, 2003**

BRUCE K. DRIVER

ABSTRACT. Math 120A Lecture notes, Fall 2003.

## 1. (9/26/03)

**1.1. Introduction.** For our purposes the definition of complex variables is the calculus of **analytic functions**, where a function  $F(x, y) = (u(x, y), v(x, y))$  from  $\mathbb{R}^2$  to itself is analytic iff it satisfies the Cauchy Riemann equations:

$$u_x = -v_y \text{ and } v_x = u_y.$$

Because this class of functions is so restrictive, the associated calculus has some very beautiful and useful properties which will be explained in this class. The following fact makes the subject useful in applications.

*Fact 1.1.* Many of the common elementary functions, like  $x^n$ ,  $e^x$ ,  $\sin x$ ,  $\tan x$ ,  $\ln x$ , etc. have **unique** “extensions” to analytic functions. Moreover, the solutions to many ordinary differential equations extend to analytic functions. So the study of analytic functions aids in understanding these class of real valued functions.

**1.2. Book Sections 1-5.**

**Definition 1.2** (Complex Numbers). Let  $\mathbb{C} = \mathbb{R}^2$  equipped with multiplication rule

$$(1.1) \quad (a, b)(c, d) \equiv (ac - bd, bc + ad)$$

and the usual rule for vector addition. As is standard we will write  $0 = (0, 0)$ ,  $1 = (1, 0)$  and  $i = (0, 1)$  so that every element  $z$  of  $\mathbb{C}$  may be written as  $z = x1 + yi$  which in the future will be written simply as  $z = x + iy$ . If  $z = x + iy$ , let  $\operatorname{Re} z = x$  and  $\operatorname{Im} z = y$ .

Writing  $z = a + ib$  and  $w = c + id$ , the multiplication rule in Eq. (1.1) becomes

$$(1.2) \quad (a + ib)(c + id) \equiv (ac - bd) + i(bc + ad)$$

and in particular  $1^2 = 1$  and  $i^2 = -1$ .

**Proposition 1.3.** *The complex numbers  $\mathbb{C}$  with the above multiplication rule satisfies the usual definitions of a field. For example  $wz = zw$  and  $z(w_1 + w_2) = zw_1 + zw_2$ , etc. Moreover if  $z \neq 0$ ,  $z$  has a multiplicative inverse given by*

$$(1.3) \quad z^{-1} = \frac{a}{a^2 + b^2} - i \frac{b}{a^2 + b^2}.$$

*Probably the most painful thing to check directly is the associative law, namely*

$$(1.4) \quad u(vw) = (uv)w.$$

*This can be checked later in polar form easier.*

**Proof.** Suppose  $z = a + ib \neq 0$ , we wish to find  $w = c + id$  such that  $zw = 1$  and this happens by Eq. (1.2) iff

$$(1.5) \quad ac - bd = 1 \text{ and}$$

$$(1.6) \quad bc + ad = 0.$$

Now taking  $a(1.5) + b(1.6)$  implies  $(a^2 + b^2)c = a$  and so  $c = \frac{a}{a^2 + b^2}$  and taking  $-b(1.5) + a(1.6)$  implies  $(a^2 + b^2)d = -b$  and hence  $d = -\frac{b}{a^2 + b^2}$  as claimed. ■

*Remark 1.4* (Not Done in Class). Here is a way to understand some of the basic properties of  $\mathbb{C}$  using our knowledge of linear algebra. Let  $M_z$  denote multiplication by  $z = a + ib$  then if  $w = c + id$  we have

$$M_z w = \begin{pmatrix} ac - bd \\ bc + ad \end{pmatrix} = \begin{pmatrix} a & -b \\ b & a \end{pmatrix} \begin{pmatrix} c \\ d \end{pmatrix}$$

so that  $M_z = \begin{pmatrix} a & -b \\ b & a \end{pmatrix} = aI + bJ$  where  $J := \begin{pmatrix} 0 & -1 \\ 1 & 0 \end{pmatrix}$ . With this notation we have  $M_z M_w = M_{zw}$  and since  $I$  and  $J$  commute it follows that  $zw = wz$ . Moreover, since matrix multiplication is associative so is complex multiplication, i.e. Eq. (1.4) holds. Also notice that  $M_z$  is invertible iff  $\det M_z = a^2 + b^2 = |z|^2 \neq 0$  in which case

$$M_z^{-1} = \frac{1}{|z|^2} \begin{pmatrix} a & b \\ -b & a \end{pmatrix} = M_{\bar{z}/|z|^2}$$

as we have already seen above.

**Notation 1.5.** We will write  $1/z$  for  $z^{-1}$  and  $w/z$  to mean  $z^{-1} \cdot w$ .

**Notation 1.6** (Conjugation and Modulus). If  $z = a + ib$  with  $a, b \in \mathbb{R}$  let  $\bar{z} = a - ib$  and

$$|z|^2 \equiv z\bar{z} = a^2 + b^2.$$

Notice that

$$(1.7) \quad \operatorname{Re} z = \frac{1}{2}(z + \bar{z}) \quad \text{and} \quad \operatorname{Im} z = \frac{1}{2i}(z - \bar{z}).$$

**Proposition 1.7.** *Complex conjugation and the modulus operators satisfy,*

- (1)  $\bar{\bar{z}} = z$ ,
- (2)  $\overline{z\bar{w}} = \bar{z}w$  and  $\overline{\bar{z} + \bar{w}} = z + w$ .
- (3)  $|\bar{z}| = |z|$
- (4)  $|zw| = |z||w|$  and in particular  $|z^n| = |z|^n$  for all  $n \in \mathbb{N}$ .
- (5)  $|\operatorname{Re} z| \leq |z|$  and  $|\operatorname{Im} z| \leq |z|$
- (6)  $|z + w| \leq |z| + |w|$ .
- (7)  $z = 0$  iff  $|z| = 0$ .
- (8) If  $z \neq 0$  then  $z^{-1} := \frac{\bar{z}}{|z|^2}$  (also written as  $\frac{1}{z}$ ) is the inverse of  $z$ .
- (9)  $|z^{-1}| = |z|^{-1}$  and more generally  $|z^n| = |z|^n$  for all  $n \in \mathbb{Z}$ .

**Proof.** 1. and 3. are geometrically obvious.

2. Say  $z = a + ib$  and  $w = c + id$ , then  $\bar{z}\bar{w}$  is the same as  $zw$  with  $b$  replaced by  $-b$  and  $d$  replaced by  $-d$ , and looking at Eq. (1.2) we see that

$$\bar{z}\bar{w} = (ac - bd) - i(bc + ad) = \overline{zw}.$$

4.  $|zw|^2 = zw\bar{z}\bar{w} = z\bar{z}w\bar{w} = |z|^2|w|^2$  as real numbers and hence  $|zw| = |z||w|$ .

5. Geometrically obvious or also follows from

$$|z| = \sqrt{|\operatorname{Re} z|^2 + |\operatorname{Im} z|^2}.$$

6. This is the triangle inequality which may be understood geometrically or by the computation

$$\begin{aligned} |z + w|^2 &= (z + w)(\overline{z + w}) = |z|^2 + |w|^2 + w\bar{z} + \bar{w}z \\ &= |z|^2 + |w|^2 + w\bar{z} + \overline{w\bar{z}} \\ &= |z|^2 + |w|^2 + 2\operatorname{Re}(w\bar{z}) \leq |z|^2 + |w|^2 + 2|z||w| \\ &= (|z| + |w|)^2. \end{aligned}$$

7. Obvious.

8. Follows from Eq. (1.3).

9.  $|z^{-1}| = \left| \frac{\bar{z}}{|z|^2} \right| = \left| \frac{1}{|z|^2} \right| |\bar{z}| = \frac{1}{|z|}. \quad \blacksquare$

## 2. (9/30/03)

2.1. **Left Overs.** Go over Eq. (1.7) and properties 8. and 9. in Proposition 1.7.

**Lemma 2.1.** For complex number  $u, v, w, z \in \mathbb{C}$  with  $v \neq 0 \neq z$ , we have

$$\begin{aligned} \frac{1}{u} \frac{1}{v} &= \frac{1}{uv}, \text{ i.e. } u^{-1}v^{-1} = (uv)^{-1} \\ \frac{u}{v} \frac{w}{z} &= \frac{uw}{vz} \text{ and} \\ \frac{u}{v} + \frac{w}{z} &= \frac{uz + vw}{vz}. \end{aligned}$$

**Proof.** For the first item, it suffices to check that

$$(uv)(u^{-1}v^{-1}) = u^{-1}uvv^{-1} = 1 \cdot 1 = 1.$$

The rest follow using

$$\frac{u}{v} \frac{w}{z} = uv^{-1}wz^{-1} = uww^{-1}z^{-1} = uw(vz)^{-1} = \frac{uw}{vz}.$$

$$\begin{aligned} \frac{u}{v} + \frac{w}{z} &= \frac{zu}{zv} + \frac{vw}{vz} = \frac{zu}{zv} + \frac{vw}{vz} \\ &= (vz)^{-1}(zu + vw) = \frac{uz + vw}{vz}. \end{aligned}$$

■

2.2. **Book Sections 36-37, p. 111-115.** Here we suppose  $w(t) = c(t) + id(t)$  and define

$$\dot{w}(t) = \dot{c}(t) + i\dot{d}(t)$$

and

$$\int_{\alpha}^{\beta} w(t) dt := \int_{\alpha}^{\beta} c(t) dt + i \int_{\alpha}^{\beta} d(t) dt$$

**Example 2.2.**

$$\int_0^{\pi/2} (e^t + i \sin t) dt = e^{\frac{1}{2}\pi} - 1 + i.$$

**Theorem 2.3.** If  $z(t) = a(t) + ib(t)$  and  $w(t) = c(t) + id(t)$  and  $\lambda = u + iv \in \mathbb{C}$  then

- (1)  $\frac{d}{dt}(w(t) + z(t)) = \dot{w}(t) + \dot{z}(t)$
- (2)  $\frac{d}{dt}[w(t)z(t)] = w\dot{z} + \dot{w}z$
- (3)  $\int_{\alpha}^{\beta} [w(t) + \lambda z(t)] dt = \int_{\alpha}^{\beta} w(t) dt + \lambda \int_{\alpha}^{\beta} z(t) dt$
- (4)  $\int_{\alpha}^{\beta} \dot{w}(t) dt = w(\beta) - w(\alpha)$  In particular if  $\dot{w} = 0$  then  $w$  is constant.
- (5)

$$\int_{\alpha}^{\beta} \dot{w}(t)z(t) dt = - \int_{\alpha}^{\beta} w(t)\dot{z}(t) dt + w(t)z(t) \Big|_{\alpha}^{\beta}.$$

(6)

$$\left| \int_{\alpha}^{\beta} w(t) dt \right| \leq \int_{\alpha}^{\beta} |w(t)| dt.$$

**Proof.** 1. and 4. are easy.

2.

$$\begin{aligned} \frac{d}{dt} [wz] &= \frac{d}{dt} (ac - bd) + i \frac{d}{dt} (bc + ad) \\ &= (\dot{a}c - \dot{b}d) + i(\dot{b}c + \dot{a}d) \\ &\quad + (a\dot{c} - b\dot{d}) + i(b\dot{c} + a\dot{d}) \\ &= \dot{w}z + w\dot{z}. \end{aligned}$$

3. The only interesting thing to check is that

$$\int_{\alpha}^{\beta} \lambda z(t) dt = \lambda \int_{\alpha}^{\beta} z(t) dt.$$

Again we simply write out the real and imaginary parts:

$$\begin{aligned} \int_{\alpha}^{\beta} \lambda z(t) dt &= \int_{\alpha}^{\beta} (u + iv)(a(t) + ib(t)) dt \\ &= \int_{\alpha}^{\beta} (ua(t) - vb(t) + i[ub(t) + va(t)]) dt \\ &= \int_{\alpha}^{\beta} (ua(t) - vb(t)) dt + i \int_{\alpha}^{\beta} [ub(t) + va(t)] dt \end{aligned}$$

while

$$\begin{aligned} \int_{\alpha}^{\beta} \lambda z(t) dt &= (u + iv) \int_{\alpha}^{\beta} [a(t) + ib(t)] dt \\ &= (u + iv) \left( \int_{\alpha}^{\beta} a(t) dt + i \int_{\alpha}^{\beta} b(t) dt \right) \\ &= \int_{\alpha}^{\beta} (ua(t) - vb(t)) dt + i \int_{\alpha}^{\beta} [ub(t) + va(t)] dt. \end{aligned}$$

**Shorter Alternative:** Just check it for  $\lambda = i$ , this is the only new thing over the real variable theory.

5.

$$w(t)z(t)|_{\alpha}^{\beta} = \int_{\alpha}^{\beta} \frac{d}{dt} [w(t)z(t)] dt = \int_{\alpha}^{\beta} \dot{w}(t)z(t) dt + \int_{\alpha}^{\beta} w(t)\dot{z}(t) dt.$$

6. Let  $\rho \geq 0$  and  $\theta \in \mathbb{R}$  be chosen so that

$$\int_{\alpha}^{\beta} w(t) dt = \rho e^{i\theta},$$

then

$$\begin{aligned} \left| \int_{\alpha}^{\beta} w(t) dt \right| &= \rho = e^{-i\theta} \int_{\alpha}^{\beta} w(t) dt = \int_{\alpha}^{\beta} e^{-i\theta} w(t) dt \\ &= \int_{\alpha}^{\beta} \operatorname{Re} [e^{-i\theta} w(t)] dt \leq \int_{\alpha}^{\beta} |\operatorname{Re} [e^{-i\theta} w(t)]| dt \\ &\leq \int_{\alpha}^{\beta} |e^{-i\theta} w(t)| dt = \int_{\alpha}^{\beta} |w(t)| dt. \end{aligned}$$

■

**2.3. Application.** We would like to use the above ideas to find a “natural” extension of the function  $e^x$  to a function  $e^z$  with  $z \in \mathbb{C}$ . The idea is that since

$$\frac{d}{dt}e^{tx} = xe^{tx} \text{ with } e^{0x} = 1$$

we might try to define  $e^z$  so that

$$(2.1) \quad \frac{d}{dt}e^{tz} = ze^{tz} \text{ with } e^{0z} = 1.$$

**Proposition 2.4.** *If there is a function  $e^z$  such that Eq. (2.1) holds, then it satisfies:*

- (1)  $e^{-z} = \frac{1}{e^z}$  and
- (2)  $e^{w+z} = e^w e^z$ .

**Proof.** 1. By the product rule,

$$\frac{d}{dt} [e^{-tz} e^{tz}] = -ze^{-tz} e^{tz} + e^{-tz} ze^{tz} = 0$$

and therefore,  $e^{-tz} e^{tz} = e^{-0z} e^{0z} = 1$ . Taking  $t = 1$  proves 1.

2. Again by the product rule,

$$\frac{d}{dt} [e^{-t(w+z)} e^{tw} e^{tz}] = 0$$

and so  $e^{-t(w+z)} e^{tw} e^{tz} = e^{-t(w+z)} e^{tw} e^{tz}|_{t=0} = 1$ . Taking  $t = 1$  then shows  $e^{-(w+z)} e^w e^z = 1$  and then using Item 1. proves Item 2. ■

According to Proposition 2.4, to find the desired function  $e^z$  it suffices to find  $e^{iy}$ . So let us write

$$e^{it} = x(t) + iy(t)$$

then by assumption  $\frac{d}{dt}e^{it} = ie^{it}$  with  $e^{i0} = 1$  implies

$$\dot{x} + i\dot{y} = i(x + iy) = -y + ix \text{ with } x(0) = 1 \text{ and } y(0) = 0$$

or equivalently that

$$\dot{x} = -y, \quad \dot{y} = x \text{ with } x(0) = 1 \text{ and } y(0) = 0.$$

This equation implies

$$\ddot{x}(t) = -\dot{y}(t) = -x(t) \text{ with } x(0) = 1 \text{ and } \dot{x}(0) = 0$$

which has the unique solution  $x(t) = \cos t$  in which case  $y(t) = -\frac{d}{dt} \cos t = \sin t$ . This leads to the following definition.

**Definition 2.5** (Euler’s Formula). For  $\theta \in \mathbb{R}$  let  $e^{i\theta} := \cos \theta + i \sin \theta$  and for  $z = x + iy$  let

$$(2.2) \quad e^z = e^x e^{iy} = e^x (\cos y + i \sin y).$$

Quickly review  $e^z$  and its properties, in particular Euler’s formula.

**Theorem 2.6.** *The function  $e^z$  defined by Eq. (2.2) satisfies Eq. (2.1) and hence the results of Proposition 2.4. Also notice that  $\overline{e^z} = e^{\bar{z}}$ .*

**Proof.** This is proved on p. 112 of the book and the proof goes as follows,

$$\frac{d}{dt} e^{tz} = \frac{d}{dt} [e^{tx} e^{ity}] = x e^{tx} e^{ity} + e^{tx} i y e^{ity} = z e^{tx} e^{ity} = z e^{tz}.$$

The last equality follows from

$$\begin{aligned} \overline{e^z} &= \overline{e^x (\cos y + i \sin y)} = \overline{e^x} \overline{(\cos y + i \sin y)} = e^x (\cos y - i \sin y) \\ &= e^x (\cos(-y) + i \sin(-y)) = e^{\bar{z}}. \end{aligned}$$

■

**Corollary 2.7** (Addition formulas). *For  $\alpha, \beta \in \mathbb{R}$  we have*

$$\begin{aligned} \cos(\alpha + \beta) &= \cos \alpha \cos \beta - \sin \alpha \sin \beta \\ \sin(\alpha + \beta) &= \cos \alpha \sin \beta + \cos \beta \sin \alpha. \end{aligned}$$

**Proof.** These follow by comparing the real and imaginary parts of the identity

$$e^{i\alpha} e^{i\beta} = e^{i(\alpha+\beta)} = \cos(\alpha + \beta) + i \sin(\alpha + \beta)$$

while

$$\begin{aligned} e^{i\alpha} e^{i\beta} &= (\cos \alpha + i \sin \alpha) \cdot (\cos \beta + i \sin \beta) \\ &= \cos \alpha \cos \beta - \sin \alpha \sin \beta + i (\cos \alpha \sin \beta + \cos \beta \sin \alpha). \end{aligned}$$

■



## 3. (10/1/03)

**Exercise 3.1.** Suppose  $a, b \in \mathbb{R}$ , show

$$\int_0^T e^{at} e^{ibt} dt = \int_0^T e^{(a+ib)t} dt = \int_0^T \frac{1}{a+ib} \frac{d}{dt} e^{(a+ib)t} dt = \frac{1}{a+ib} [e^{aT} e^{ibT} - 1].$$

By comparing the real and imaginary parts of both sides of this integral find explicit formulas for the two real integrals

$$\int_0^T e^{at} \cos(bt) dt \text{ and}$$

$$\int_0^T e^{at} \sin(bt) dt.$$

**3.1. Polar/Exponential Form of Complex Numbers: Sections 6 – 9.** Bruce: Give the geometric interpretation of each of the following properties.

- (1)  $z = re^{i\theta} = |z| e^{i\theta}$ .
- (2)  $\bar{z} = |z| e^{-i\theta}$  and  $z^{-1} = \bar{z}/|z|^2 = |z|^{-1} e^{-i\theta}$
- (3) If  $w = |w| e^{i\alpha}$  then

$$zw = |z| |w| e^{i(\theta+\alpha)} \text{ and}$$

$$z/w = zw^{-1} = |z| e^{i\theta} \cdot |w|^{-1} e^{-i\alpha} = |z| |w|^{-1} e^{i(\theta-\alpha)}.$$

In particular

$$z^n = |z|^n e^{in\theta} \text{ for } n \in \mathbb{Z}.$$

**Notation 3.2.** If  $z \neq 0$  we let  $\theta = \text{Arg}(z)$  if  $-\pi < \theta \leq \pi$  and  $z = |z| e^{i\theta}$  while we define

$$\arg(z) = \{\theta \in \mathbb{R} : z = |z| e^{i\theta}\}.$$

Notice that

$$\arg(z) = \text{Arg}(z) + 2\pi\mathbb{Z}.$$

Similarly we define  $\text{Log}(z) = \ln|z| + i\text{Arg}(z)$  and

$$\log(z) = \ln|z| + i\arg(z) = \ln|z| + i\text{Arg}(z) + 2\pi i\mathbb{Z}.$$

**Example 3.3.**

- (1) Work out  $(1+i)(\sqrt{3}+i)$  in polar form.

$$(1+i)(\sqrt{3}+i) = \sqrt{2}e^{i\pi/4} \cdot 2e^{i\pi/6} = 2\sqrt{2}e^{i5\pi/12}.$$

Note here that

$$\arg(1+i) = \pi/4 + 2\pi\mathbb{Z} \text{ and } \arg(\sqrt{3}+i) = \pi/6 + 2\pi\mathbb{Z}$$

$$\text{Arg}(1+i) = \pi/4 \text{ and } \text{Arg}(\sqrt{3}+i) = \pi/6$$

- (2) Let  $\alpha = \tan^{-1}(1/2)$  then

$$\frac{5i}{2+i} = \frac{5e^{i\pi/2}}{\sqrt{5}e^{i\tan^{-1}(1/2)}} = \sqrt{5}e^{i(\pi/2-\tan^{-1}(1/2))} = 1+2i$$

by drawing the triangles.

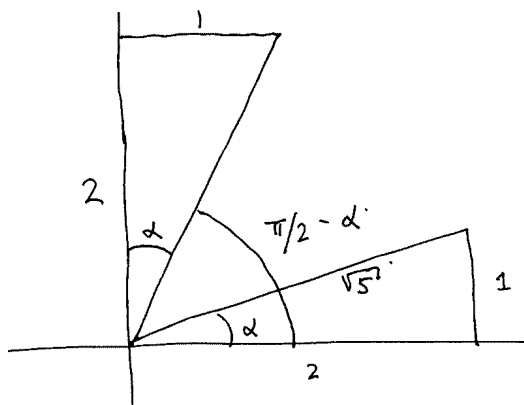

- (3) General theory of finding  $n^{\text{th}}$  - roots if a number  $z = \rho e^{i\alpha}$ . Let  $w = r e^{i\theta}$  then  $z = \rho e^{i\alpha} = w^n = r^n e^{in\theta}$  happens iff

$$\rho = |z| = |w^n| = |w|^n = r^n \text{ or } r = \rho^{1/n} \text{ and}$$

$$e^{i\alpha} = e^{in\theta} \text{ i.e. } e^{i(n\theta - \alpha)} = 1, \text{ i.e. } n\theta - \alpha \in 2\pi\mathbb{Z}.$$

Therefore

$$z^{1/n} = |z|^{1/n} e^{i\frac{1}{n}(\alpha + 2\pi\mathbb{Z})} = |z|^{1/n} e^{i\frac{1}{n}\arg(z)}$$

$$= \left\{ |z|^{1/n} e^{i\frac{1}{n}(\alpha + 2\pi k)} : k = 0, 1, 2, \dots, n-1 \right\}.$$

- (4) Find all fourth roots of  $(1+i)$ .

$$(1+i) = \sqrt{2} e^{i(\pi/4 + 2\pi\mathbb{Z})}$$

and so

$$(1+i)^{1/4} = 2^{1/8} e^{i(\pi/16 + \frac{1}{8}\pi\mathbb{Z})} = \left\{ 2^{1/8} e^{i(\pi/16 + \frac{1}{2}\pi k)} : k = 0, 1, 2, 3 \right\}.$$

## 4. (10/03/2003)

## 4.1. More on Roots and multi-valued arithmetic.

**Notation 4.1.** Suppose  $A \subset \mathbb{C}$  and  $B \subset \mathbb{C}$ , then we let

$$A \cdot B := \{ab : a \in A \text{ and } b \in B\} \text{ and}$$

$$A \pm B := \{a \pm b : a \in A \text{ and } b \in B\}.$$

**Proposition 4.2.**  $\arg(zw) = \arg(z) + \arg(w)$  while it is not in general true the  $\text{Arg}(zw) = \text{Arg}(z) + \text{Arg}(w)$ .

**Proof.** Suppose  $z = |z|e^{i\theta}$  and  $w = |w|e^{i\alpha}$ , then

$$\arg(zw) = (\theta + \alpha + 2\pi\mathbb{Z})$$

while

$$\arg(z) + \arg(w) = (\theta + 2\pi\mathbb{Z}) + (\alpha + 2\pi\mathbb{Z}) = (\theta + \alpha + 2\pi\mathbb{Z}).$$

Example: Let  $z = i$  and  $w = -1$ , then  $\text{Arg}(i) = \pi/2$  and  $\text{Arg}(-1) = \pi$  so that

$$\text{Arg}(i) + \text{Arg}(-1) = \frac{3\pi}{2}$$

while

$$\text{Arg}(i \cdot (-1)) = -\pi/2.$$

■

The following proposition summarizes item 3. of Example 3.3 above and gives an application of Proposition 4.2.

**Proposition 4.3.** Suppose that  $w \in \mathbb{C}$ , then the set of  $n^{\text{th}}$  - roots,  $w^{1/n}$  of  $w$  is

$$w^{1/n} = \sqrt[n]{|w|}e^{i\frac{1}{n}\arg(w)}.$$

Moreover if  $z \in \mathbb{C}$  then

$$(4.1) \quad (wz)^{1/n} = w^{1/n} \cdot z^{1/n}$$

In particular this implies if  $w_0$  is an  $n^{\text{th}}$  - root of  $w$ , then

$$w^{1/n} = \left\{ w_0 e^{i\frac{k}{n}2\pi} : k = 0, 1, \dots, n-1 \right\}.$$

DRAW picture of the placement of the roots on the circle of radius  $\sqrt[n]{|w|}$ .

**Proof.** It only remains to prove Eq. (4.1) and this is done using

$$\begin{aligned} w^{1/n} \cdot z^{1/n} &= \sqrt[n]{|w|}e^{i\frac{1}{n}\arg(w)} \sqrt[n]{|z|}e^{i\frac{1}{n}\arg(z)} \\ &= \sqrt[n]{|w||z|}e^{i\frac{1}{n}[\arg(w)+\arg(z)]} = \sqrt[n]{|wz|}e^{i\frac{1}{n}\arg(wz)} \\ &= (wz)^{1/n}. \end{aligned}$$

■

**Theorem 4.4** (Quadratic Formula). Suppose  $a, b, c \in \mathbb{C}$  with  $a \neq 0$  then the general solution to the equation

$$az^2 + bz + c = 0$$

is

$$z = \frac{-b \pm (b^2 - 4ac)^{1/2}}{2a}.$$

**Proof.** The proof goes as in the real case by observing

$$0 = az^2 + bz + c = a \left( z + \frac{b}{2a} \right)^2 + c - \frac{b^2}{4a}$$

and so

$$\left( z + \frac{b}{2a} \right)^2 = \frac{b^2 - 4ac}{4a^2}.$$

Taking square roots of this equation then shows

$$z + \frac{b}{2a} = \frac{(b^2 - 4ac)^{1/2}}{2a}$$

which is the quadratic formula. ■

#### 4.2. Regions and Domains:

(1) Regions in the plane. **Definition:** a domain is a **connected open** subset of  $\mathbb{C}$ . Examples:

- (a)  $\{z : |z - 1 + 2i| < 4\}$ .
- (b)  $\{z : |z - 1 + 2i| \leq 4\}$ .
- (c)  $\{z : |z - 1 + 2i| = 4\}$
- (d)  $\{z : z = re^{i\theta} \text{ with } r > 0 \text{ and } -\pi < \theta < \pi\}$
- (e)  $\{z : z = re^{i\theta} \text{ with } r \geq 0 \text{ and } -\pi < \theta \leq \pi\}$ .

## 5. (10/06/2003)

5.1. Functions from  $\mathbb{C}$  to  $\mathbb{C}$ .

- (1) Complex functions,  $f : D \rightarrow \mathbb{C}$ . Point out that  $f(z) = u(x, y) + iv(x, y)$  where  $z = x + iy \in D$ . Examples: (Mention domains)
- (a)  $f(z) = z$ ,  $u = x$ ,  $v = y$
  - (b)  $f(z) = z^2$ ,  $u = x^2 - y^2$ ,  $v = 2xy$  also look at it as  $f(re^{i\theta}) = r^2e^{i2\theta}$ .
    - (i) So rays through the origin go to rays through the origin.
    - (ii) Also arcs of circles centered at 0 go over to arcs of circles centered at 0.
    - (iii) Also notice that if we hold  $x$  constant, then  $y = v/2x$  and so  $u = x^2 - \frac{v^2}{4x^2}$  which is the graph of a parabola.
    - (iv) Bruce !!: Do the examples where  $\operatorname{Re} f(z) = 1$  and  $\operatorname{Im} f(z) = 1$  to get pre-images which are two hyperbolas. Explain the orientation traversed. See Figure 1 below.
  - (c)  $f(z) = az$ , if  $a = re^{i\theta}$ , then  $f(z)$  scales  $z$  by  $r$  and then rotates by  $\theta$  degrees. If  $a = \alpha + i\beta$ , then  $u = \alpha x - \beta y$ ,  $v = \alpha y + \beta x$ .
  - (d)  $f(z) = \bar{z}$ , this is reflection about the  $x$ -axis.
  - (e)  $f(z) = 1/z$  is inversion, notice that  $f(re^{i\theta}) = \frac{1}{re^{i\theta}} = \frac{1}{r}e^{-i\theta}$ , draw picture.
  - (f)  $f(z) = e^z = e^{x+iy}$ ,  $u = e^x \cos y$  and  $v = e^x \sin y$ .
    - (i) Show what happens to the line  $x = 2$  and the line  $y = \pi/4$ .
  - (g)  $f(re^{i\theta}) = r^{\frac{1}{2}}e^{i\frac{1}{2}\theta}$  for  $-\pi < \theta \leq \pi$ . Somewhat painful to write  $u, v$  in this case.

$$f(z) = z^2 = x^2 - y^2 + 2i xy = u + iv$$

$$\operatorname{Re} f(z) = 1 = x^2 - y^2 = u$$

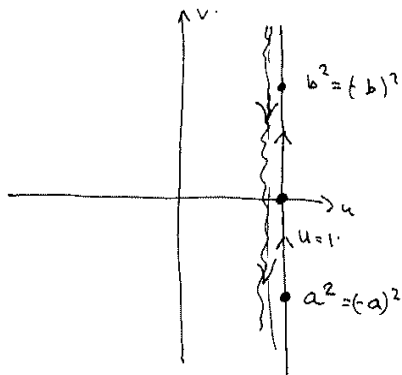
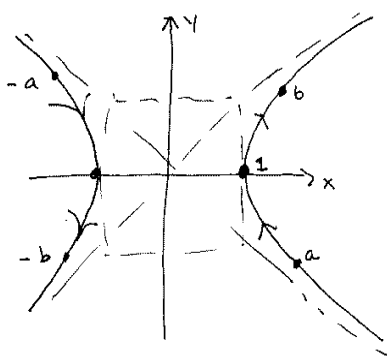

$$\operatorname{Im} f(z) = 1 = v = 2xy$$

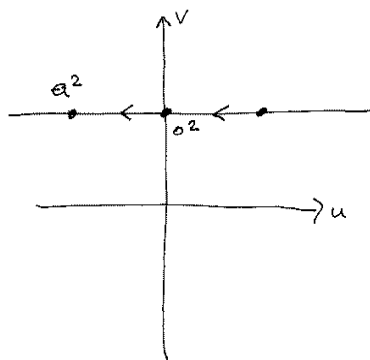
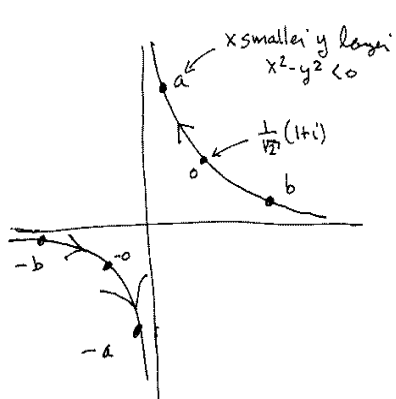
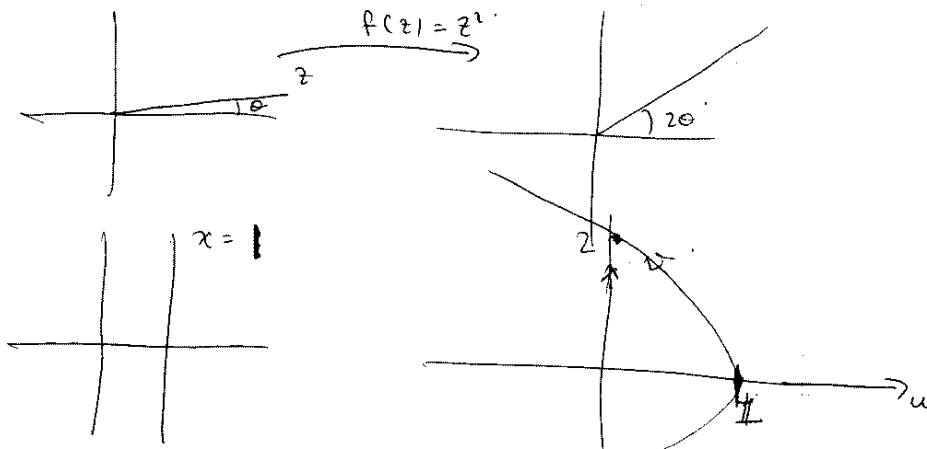

FIGURE 1. Pre-images of lines for  $f(z) = z^2$ .

Explain. Image of rays -



$$f(z) = (1+iy)^2 = 1-y^2 + i2y = u + iv$$

$$1-y^2 = u \quad v = 2y \quad y = v/2$$

$$u = 1 - \frac{v^2}{4} \quad u=0 \quad 4 \cdot 4^2 = v^2 \quad v = \sqrt{2} \cdot 4$$

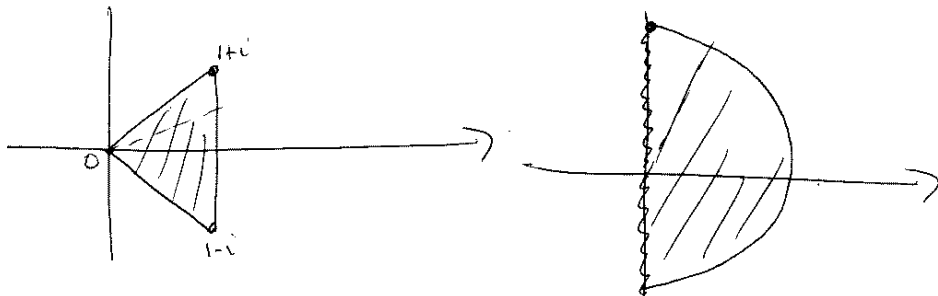

Examples

- $z \rightarrow az \quad a > 0$
- $z \rightarrow e^{i\theta} z$
- $z \rightarrow z + z_0$
- $z \rightarrow \frac{1}{z}$

dilate  
rotation by  $\theta$   
translation  
inverse

## 5.2. Continuity and Limits.

5.3.  $\varepsilon$  – **Notation.** In this section,  $U$  will be an open subset of  $\mathbb{C}$ ,  $f : U \rightarrow \mathbb{C}$  a function and  $\varepsilon(z)$  will denote a generic function defined for  $z$  near zero such that  $\lim_{z \rightarrow 0} \varepsilon(z) = 0$ .

**Definition 5.1.** (1)  $\lim_{z \rightarrow z_0} f(z) = L$  iff  $f(z_0 + \Delta z) = L + \varepsilon(\Delta z)$   
 (2)  $f$  is continuous at  $z_0$  if  $\lim_{z \rightarrow z_0} f(z) = f(z_0) = f(\lim_{z \rightarrow z_0} z)$ .  
 (3)  $f$  is differentiable at  $z_0$  with derivative  $L$  iff

$$\lim_{z \rightarrow z_0} \frac{f(z) - f(z_0)}{z - z_0} = L$$

or equivalently iff

$$(5.1) \quad \frac{f(z_0 + \Delta z) - f(z_0)}{\Delta z} = \frac{f(z_0 + \Delta z) - f(z_0)}{z_0 + \Delta z - z_0} = L + \varepsilon(\Delta z)$$

or equivalently,

$$(5.2) \quad f(z_0 + \Delta z) - f(z_0) = (L + \varepsilon(\Delta z)) \Delta z.$$

**Proposition 5.2.** *The functions  $f(z) := \bar{z}$ ,  $f(z) = \operatorname{Re} z$ , and  $f(z) = \operatorname{Im} z$  are all continuous functions which are **not** complex differentiable at any point  $z \in \mathbb{C}$ . The following functions are complex differentiable at all points  $z \in \mathbb{C}$ :*

- (1)  $f(z) = z$  with  $f'(z) = 1$ .
- (2)  $f(z) = \frac{1}{z}$  with  $f'(z) = -z^{-2}$ .
- (3)  $f(z) = e^z$  with  $f'(z) = e^z$ .

**Proof.** For the first assertion we have

$$\begin{aligned} |z_0 + \Delta z - \bar{z}_0| &= |\Delta z| \rightarrow 0 \\ |\operatorname{Re}(z_0 + \Delta z) - \operatorname{Re} z_0| &= |\operatorname{Re} \Delta z| \leq |\Delta z| \rightarrow 0 \text{ and} \\ |\operatorname{Im}(z_0 + \Delta z) - \operatorname{Im} z_0| &= |\operatorname{Im} \Delta z| \leq |\Delta z| \rightarrow 0. \end{aligned}$$

For differentiability,

$$\frac{f(z + \Delta z) - f(z)}{\Delta z} = \frac{\overline{\Delta z}}{\Delta z}$$

which has no limit as  $\Delta z \rightarrow 0$ . Indeed, consider what happens for  $\Delta z = x$  and  $\Delta z = iy$  with  $x, y \in \mathbb{R}$  and  $x, y \rightarrow 0$ . Similarly

$$\frac{\operatorname{Re}(z_0 + \Delta z) - \operatorname{Re} z_0}{\Delta z} = \frac{\operatorname{Re} \Delta z}{\Delta z}$$

as no limit as  $\Delta z \rightarrow 0$ .

(1)

$$\frac{f(z + \Delta z) - f(z)}{\Delta z} = 1 \rightarrow 1 \text{ as } \Delta z \rightarrow 0.$$

(2) Let us first shows that  $1/z$  is continuous, for this we have

$$\begin{aligned} |(z + \Delta z)^{-1} - z^{-1}| &= \left| \frac{z - (z + \Delta z)}{z(z + \Delta z)} \right| = \left| \frac{1}{z} \right| \left| \frac{1}{z + \Delta z} \right| |\Delta z| \\ &\leq \left| \frac{1}{z} \right| \left| \frac{1}{|z| - |\Delta z|} \right| |\Delta z| \leq \frac{2}{|z|^2} |\Delta z| \rightarrow 0. \end{aligned}$$



We now use this to compute the derivative,

$$\begin{aligned} \frac{f(z + \Delta z) - f(z)}{\Delta z} &= \frac{(z + \Delta z)^{-1} - z^{-1}}{\Delta z} \\ &= \frac{\frac{1}{z + \Delta z} - \frac{1}{z}}{\Delta z} = \frac{1}{\Delta z} \frac{z - (z + \Delta z)}{z(z + \Delta z)} = -\frac{1}{z(z + \Delta z)} \rightarrow -\frac{1}{z^2}. \end{aligned}$$

where the continuity of  $1/z$  was used in taking the limit.

(3) Since

$$\frac{e^{z+\Delta z} - e^z}{\Delta z} = e^z \frac{e^{\Delta z} - 1}{\Delta z}$$

it suffices to show

$$\frac{e^{\Delta z} - 1}{\Delta z} \rightarrow 1 \text{ as } \Delta z \rightarrow 0.$$

This follows from,

$$\frac{e^{\Delta z} - 1}{\Delta z} = \frac{1}{\Delta z} \int_0^1 \frac{d}{dt} e^{t\Delta z} dt = \frac{1}{\Delta z} \Delta z \int_0^1 e^{t\Delta z} dt = \int_0^1 e^{t\Delta z} dt$$

which implies

$$e^{\Delta z} - 1 = \Delta z \int_0^1 e^{t\Delta z} dt = \varepsilon(\Delta z)$$

and therefore

$$\left| \frac{e^{\Delta z} - 1}{\Delta z} - 1 \right| = \left| \int_0^1 [e^{t\Delta z} - 1] dt \right| \leq \int_0^1 |e^{t\Delta z} - 1| dt = \int_0^1 |\varepsilon(t\Delta z)| dt \rightarrow 0 \text{ as } \Delta z \rightarrow 0.$$

**Alternative 1.**,

$$\begin{aligned} \int_0^1 e^{t\Delta z} dt &= \int_0^1 e^{t\Delta z} d[t - 1] \\ &= (e^{t\Delta z} [t - 1])_0^1 - \int_0^1 \frac{d}{dt} e^{t\Delta z} [t - 1] dt \\ &= 1 - \Delta z \int_0^1 e^{t\Delta z} [t - 1] dt \end{aligned}$$

from which it should be clear that

$$\frac{e^{\Delta z} - 1}{\Delta z} - 1 = \varepsilon(\Delta z).$$

**Alternative 2.** Write  $\Delta z = x + iy$ , then and use the definition of the real derivative to learn

$$\begin{aligned} e^{\Delta z} &= e^{x+iy} = e^x (\cos y + i \sin y) = (1 + x + O(x^2)) (1 + iy + O(y^2)) \\ &= 1 + x + iy + O(|\Delta z|^2) = 1 + \Delta z + O(|\Delta z|^2). \end{aligned}$$

■

## 6. (10/08/2003 AND 10/10/2003) LECTURES 6-7

Go over the function  $f(z) = e^z$  in a bit more detail than was done in class using **Alternative 2** above to show

$$(6.1) \quad \lim_{\Delta z \rightarrow 0} \frac{e^{\Delta z} - 1}{\Delta z} = 1$$

To do this write  $\Delta z = x + iy$ , then and use Taylor's formula with remainder for real functions to learn

$$\begin{aligned} e^{\Delta z} &= e^{x+iy} = e^x (\cos y + i \sin y) = (1 + x + O(x^2)) (1 + iy + O(y^2)) \\ &= 1 + x + iy + O(|\Delta z|^2) = 1 + \Delta z + O(|\Delta z|^2) \end{aligned}$$

which implies Eq. (6.1).

**Exercise 6.1.** Suppose that  $f'(0) = 5$  and  $g(z) = f(\bar{z})$ . Show  $g'(0)$  does not exist.

**Solution:**

$$\frac{g(z) - g(0)}{z} = \frac{f(\bar{z}) - f(0)}{z} = \frac{(5 + \epsilon(\bar{z})) \bar{z}}{z}$$

and the latter does not have a limit by Proposition 5.2.

BRUCE: Do **examples** in this section before giving proofs.

**Definition 6.2.** Limits involving  $\infty$ ,

- (1)  $\lim_{z \rightarrow \infty} f(z) = w$  iff  $\lim_{z \rightarrow 0} f(1/z) = w$ .
- (2)  $\lim_{z \rightarrow w} f(z) = \infty$  iff  $\lim_{z \rightarrow w} \frac{1}{f(z)} = 0$ .
- (3)  $\lim_{z \rightarrow \infty} f(z) = \infty$  iff  $\lim_{z \rightarrow 0} \frac{1}{f(1/z)} = 0$ .

BRUCE: Explain the motivation via stereographic projection, see Figure 2.

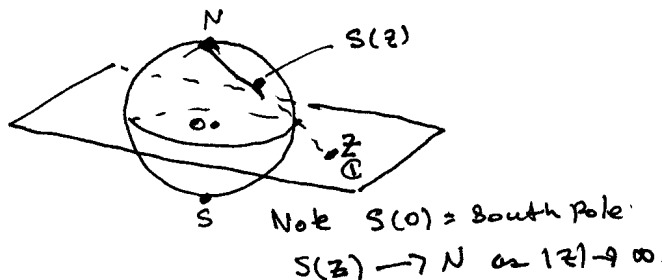

FIGURE 2. The picture behind the limits at infinity.

**Theorem 6.3.** If  $\lim_{z \rightarrow z_0} f(z) = L$  and  $\lim_{z \rightarrow z_0} g(z) = K$  then

- (1)  $\lim_{z \rightarrow z_0} [f(z) + g(z)] = L + K$ .
- (2)  $\lim_{z \rightarrow z_0} [f(z)g(z)] = LK$
- (3) If  $z \rightarrow h(z) = f(g(z))$  is continuous at  $z_0$  if  $g$  is continuous at  $z_0$  and  $f$  is continuous at  $w_0 = g(z_0)$ .
- (4)  $\lim_{z \rightarrow z_0} \left[ \frac{f(z)}{g(z)} \right] = \frac{L}{K}$  provided  $K \neq 0$ .

- (5) We also have  $\lim_{z \rightarrow z_0} f(z) = L$  iff  $\lim_{z \rightarrow z_0} \operatorname{Re} f(z) = \operatorname{Re} L$  and  $\lim_{z \rightarrow z_0} \operatorname{Im} f(z) = \operatorname{Im} L$ .

**Proof.**

(1)

$$f(z_0 + \Delta z) + g(z_0 + \Delta z) = L + \varepsilon(\Delta z) + K + \varepsilon(\Delta z) = (L + K) + \varepsilon(\Delta z).$$

(2)

$$\begin{aligned} f(z_0 + \Delta z) \cdot g(z_0 + \Delta z) &= [L + \varepsilon(\Delta z)] \cdot [K + \varepsilon(\Delta z)] \\ &= LK + K\varepsilon(\Delta z) + L\varepsilon(\Delta z) + \varepsilon(\Delta z)\varepsilon(\Delta z) = LK + \varepsilon(\Delta z). \end{aligned}$$

(3) Well,

$$\begin{aligned} h(z_0 + \Delta z) - h(z_0) &= f(g(z_0 + \Delta z)) - f(g(z_0)) \\ &= f(g(z_0) + \varepsilon(\Delta z)) - f(g(z_0)) = \varepsilon(\varepsilon(\Delta z)) \rightarrow 0 \text{ as } \Delta z \rightarrow 0. \end{aligned}$$

(4) This follows directly using

$$\begin{aligned} \frac{f(z_0 + \Delta z)}{g(z_0 + \Delta z)} - \frac{L}{K} &= \frac{L + \varepsilon(\Delta z)}{K + \varepsilon(\Delta z)} - \frac{L}{K} = \frac{(L + \varepsilon(\Delta z))K - L(K + \varepsilon(\Delta z))}{K^2 + K\varepsilon(\Delta z)} \\ &= \frac{\varepsilon(\Delta z)}{K^2 + \varepsilon(\Delta z)} = \varepsilon(\Delta z). \end{aligned}$$

or more simply using item 3. and the fact  $1/z$  is continuous so that  $\lim_{z \rightarrow z_0} \left[ \frac{1}{g(z)} \right] = \frac{1}{K}$ .

- (5) This follows from item 1. and the continuity of the functions  $z \rightarrow \operatorname{Re} z$  and  $z \rightarrow \operatorname{Im} z$ .

■

**Theorem 6.4.** If  $f'(z_0) = L$  and  $g'(z_0) = K$  then

- (1)  $f$  is continuous at  $z_0$ ,
- (2)  $\frac{d}{dz} [f(z) + g(z)]|_{z=z_0} = L + K$
- (3)  $\frac{d}{dz} [f(z)g(z)]|_{z=z_0} = f'(z_0)g(z_0) + f(z_0)g'(z_0)$
- (4) If  $w_0 = f(z_0)$  and  $g'(w_0)$  exists then  $h(z) := g(f(z))$  is differentiable at  $z_0$  and

$$h'(z_0) = g'(f(z_0))f'(z_0).$$

(5)

$$\frac{d}{dz} \left[ \frac{f(z)}{g(z)} \right] = \frac{f'g - g'f}{g^2} \Big|_{z=z_0}.$$

- (6) If  $z(t)$  is a differentiable curve, then  $\frac{d}{dt} f(z(t)) = f'(z(t)) \dot{z}(t)$ .

**Proof.** To simplify notation, let  $\Delta f = f(z + \Delta z) - f(z)$  and  $\Delta g = g(z + \Delta z) - g(z)$  and recall that  $\Delta f \rightarrow 0$  and  $\Delta g \rightarrow 0$  as  $\Delta z \rightarrow 0$ , i.e.  $\Delta f = \varepsilon(\Delta z)$ .

- (1) This follows from Eq. (5.2).

(2)

$$\begin{aligned} \frac{[f(z + \Delta z) + g(z + \Delta z)] - [f(z) + g(z)]}{\Delta z} &= \frac{\Delta f}{\Delta z} + \frac{\Delta g}{\Delta z} \\ &\rightarrow f'(z) + g'(z) \end{aligned}$$

(3)

$$\begin{aligned}
\frac{f(z + \Delta z)g(z + \Delta z) - f(z)g(z)}{\Delta z} &= \frac{(f(z) + \Delta f)(g(z) + \Delta g) - f(z)g(z)}{\Delta z} \\
&= \frac{f(z)\Delta g + \Delta f g(z) + \Delta f \Delta g}{\Delta z} \\
&= f(z)\frac{\Delta g}{\Delta z} + g(z)\frac{\Delta f}{\Delta z} + \frac{\Delta g}{\Delta z}\Delta f \rightarrow f(z)g'(z) + g(z)f'(z).
\end{aligned}$$

(4) Recall that  $\Delta f = \varepsilon(\Delta z)$  and so

$$\begin{aligned}
\Delta h &:= h(z + \Delta z) - h(z) = g(f(z + \Delta z)) - g(f(z)) \\
&= g(f(z) + \Delta f) - g(f(z)) \\
&= [g'(f(z)) + \varepsilon(\Delta f)]\Delta f = [g'(f(z)) + \varepsilon(\Delta z)]\Delta f.
\end{aligned}$$

Therefore

$$\frac{\Delta h}{\Delta z} = [g'(f(z)) + \varepsilon(\Delta z)]\Delta f \rightarrow g'(f(z))f'(z).$$

(5) This follows from the product rule, the chain rule and the fact that  $\frac{d}{dz}z^{-1} = -z^{-2}$ .(6) In order to verify this item, we first need to observe that  $\dot{z}(t)$  exists iff  $\lim_{\Delta t \rightarrow 0} \frac{z(t+\Delta t) - z(t)}{\Delta t}$ . Recall that we defined

$$\dot{z}(t) = \frac{d}{dt} \operatorname{Re} z(t) + i \frac{d}{dt} \operatorname{Im} z(t).$$

Since the limit of a sum is a sum of a limit if  $\frac{d}{dt} \operatorname{Re} z(t)$  and  $\frac{d}{dt} \operatorname{Im} z(t)$  exist then  $\lim_{\Delta t \rightarrow 0} \frac{z(t+\Delta t) - z(t)}{\Delta t}$  exists. Conversely if  $w = \lim_{\Delta t \rightarrow 0} \frac{z(t+\Delta t) - z(t)}{\Delta t}$  exists, then

$$\begin{aligned}
\lim_{\Delta t \rightarrow 0} \left| \frac{\operatorname{Re} z(t + \Delta t) - \operatorname{Re} z(t)}{\Delta t} - \operatorname{Re} w \right| &= \lim_{\Delta t \rightarrow 0} \left| \operatorname{Re} \left( \frac{z(t + \Delta t) - z(t)}{\Delta t} - w \right) \right| \\
&\leq \lim_{\Delta t \rightarrow 0} \left| \frac{z(t + \Delta t) - z(t)}{\Delta t} - w \right| = 0
\end{aligned}$$

which shows  $\frac{d}{dt} \operatorname{Re} z(t)$  exists. Similarly one shows  $\frac{d}{dt} \operatorname{Im} z(t)$  exists as well.

Now for the proof of the chain rule: let  $\Delta z := z(t + \Delta t) - z(t)$

$$\begin{aligned}
\frac{f(z(t + \Delta t)) - f(z(t))}{\Delta t} &= \frac{[f'(z(t)) + \varepsilon(\Delta z)]\Delta z}{\Delta t} \\
&= [f'(z(t)) + \varepsilon(\Delta z)] \frac{\Delta z}{\Delta t} \rightarrow f'(z(t))\dot{z}(t).
\end{aligned}$$

■

**Example 6.5.**

- (1)  $z$  is continuous,  $\bar{z}$ ,  $\operatorname{Re} z$ ,  $\operatorname{Im} z$  are continuous and polynomials in these variables.
- (2)  $\lim_{z \rightarrow z_0} z^n = z_0^n$ , Proof by induction.
- (3)  $\lim_{z \rightarrow 1} \frac{z^2 - 1}{z - 1} = \lim_{z \rightarrow 1} (z + 1) = 2$ .
- (4)  $\lim_{z \rightarrow 1} \frac{1}{z^3 - 1} = \infty$ , where by definition  $\lim_{z \rightarrow z_0} f(z) = \infty$  iff  $\lim_{z \rightarrow z_0} \frac{1}{f(z)} = 0$ .
- (5)  $\lim_{z \rightarrow \infty} \frac{z^2 + 1}{z^2 - 1} = 1$  where by definition  $\lim_{z \rightarrow \infty} f(z) = L$  iff  $\lim_{z \rightarrow 0} f\left(\frac{1}{z}\right) = L$ .

(6)  $\lim_{z \rightarrow \infty} \frac{z^{25} + 1}{z^{24} - z^6 + 7z^2 - 5} = \infty$  where by definition  $\lim_{z \rightarrow \infty} f(z) = \infty$  iff  $\lim_{z \rightarrow 0} \frac{1}{f(\frac{1}{z})} = 0$ .

(7)  $e^z$  is continuous, proof

$$e^{z_0 + \Delta z} - e^{z_0} = e^{z_0} (e^{\Delta z} - 1) = \Delta z e^{z_0} \int_0^1 e^{t\Delta z} dt = \varepsilon(\Delta z)$$

(8)  $\lim_{z \rightarrow -1} \frac{z+1}{z^2 + (1-i)z - i}$ , since  $z^2 + (1-i)z - i = 1 - (1-i) - i = 0$  at  $z = -1$  we have to factor the denominator. By the quadratic formula we have

$$\begin{aligned} z &= \frac{-(1-i) \pm \sqrt{(1-i)^2 + 4i}}{2} = \frac{-(1-i) \pm \sqrt{(1+i)^2}}{2} \\ &= \frac{-(1-i) \pm (1+i)}{2} = \{i, -1\} \end{aligned}$$

and thus

$$z^2 + (1-i)z - i = (z-i)(z+1)$$

and we thus have

$$\lim_{z \rightarrow -1} \frac{z+1}{z^2 + (1-i)z - i} = \lim_{z \rightarrow -1} \frac{z+1}{(z-i)(z+1)} = \frac{1}{-1-i} = -\frac{1-i}{2}.$$

**Example 6.6.** Describe lots of analytic functions and compute their derivatives: for example  $z^2$ ,  $p(z)$ ,  $e^{z^2}$ ,  $e^{1/z}$ ,  $\sin(z)$   $\cos(z)$ , etc.

**Example 6.7** (Important Example).

$$\int_0^1 (1+it)^3 dt = \frac{1}{4i} (1+it)^4 \Big|_0^1 = \frac{1}{4i} [(1+i)^4 - 1] = \frac{5}{4}i.$$

If we did this the old fashion way it would be done as follows

$$\int_0^1 (1+it)^3 dt = \int_0^1 [1 + 3it - 3t^2 - it^3] dt = 1 - 1 + i \left( \frac{3}{2} - \frac{1}{4} \right) = \frac{5}{4}i.$$

**Example 6.8.**

$$\begin{aligned} \int_0^{\pi/2} e^{(1+i)\pi \sin t} \cos t dt &= \frac{1}{\pi} \frac{e^{(1+i)\pi \sin t}}{1+i} = \frac{1}{\pi} \frac{1}{1+i} [e^{\pi(1+i)} - 1] \\ &= \frac{1}{\pi} \frac{1}{1+i} [-e^\pi - 1]. \end{aligned}$$

## 7. STUDY GUIDE FOR MATH 120A MIDTERM 1 (FRIDAY OCTOBER 17, 2003)

- (1)  $\mathbb{C} := \{z = x + iy : x, y \in \mathbb{R}\}$  with  $i^2 = -1$  and  $\bar{z} = x - iy$ . The complex numbers behave much like the real numbers. In particular the quadratic formula holds.
- (2)  $|z| = \sqrt{x^2 + y^2} = \sqrt{z\bar{z}}$ ,  $|zw| = |z||w|$ ,  $|z + w| \leq |z| + |w|$ ,  $\operatorname{Re} z = \frac{z + \bar{z}}{2}$ ,  $\operatorname{Im} z = \frac{z - \bar{z}}{2i}$ ,  $|\operatorname{Re} z| \leq |z|$  and  $|\operatorname{Im} z| \leq |z|$ . We also have  $\overline{z\bar{w}} = \bar{z}\bar{w}$  and  $\overline{z + w} = \bar{z} + \bar{w}$  and  $z^{-1} = \frac{\bar{z}}{|z|^2}$ .
- (3)  $\{z : |z - z_0| = \rho\}$  is a circle of radius  $\rho$  centered at  $z_0$ .  
 $\{z : |z - z_0| < \rho\}$  is the open disk of radius  $\rho$  centered at  $z_0$ .  
 $\{z : |z - z_0| \geq \rho\}$  is every thing outside of the open disk of radius  $\rho$  centered at  $z_0$ .
- (4)  $e^z = e^x (\cos y + i \sin y)$ , every  $z = |z| e^{i\theta}$ .
- (5)  $\arg(z) = \{\theta \in \mathbb{R} : z = |z| e^{i\theta}\}$  and  $\operatorname{Arg}(z) = \theta$  if  $-\pi < \theta \leq \pi$  and  $z = |z| e^{i\theta}$ . Notice that  $z = |z| e^{i \arg(z)}$
- (6)  $z^{1/n} = \sqrt[n]{|z|} e^{i \frac{\arg(z)}{n}}$ .
- (7)  $\lim_{z \rightarrow z_0} f(z) = L$ . Usual limit rules hold from real variables.
- (8) Mapping properties of simple complex functions
- (9) The definition of complex differentiable  $f(z)$ . Examples,  $p(z)$ ,  $e^z$ ,  $e^{p(z)}$ ,  $1/z$ ,  $1/p(z)$  etc.
- (10) Key points of  $e^z$  are is  $\frac{d}{dz} e^z = e^z$  and  $e^z e^w = e^{z+w}$ .
- (11) All of the usual derivative formulas hold, in particular product, sum, and chain rules:

$$\frac{d}{dz} f(g(z)) = f'(g(z)) g'(z)$$

and

$$\frac{d}{dt} f(z(t)) = f'(z(t)) \dot{z}(t).$$

- (12)  $\operatorname{Re} z$ ,  $\operatorname{Im} z$ ,  $\bar{z}$ , are nice functions from the real - variables point of view but are **not** complex differentiable.
- (13) Integration:

$$\int_a^b z(t) dt := \int_a^b x(t) dt + i \int_a^b y(t) dt.$$

All of the usual integration rules hold, like the fundamental theorem of calculus, linearity and integration by parts.

8. (10/13/2003) LECTURE 8

**Definition 8.1** (Analytic and entire functions). A function  $f : D \rightarrow \mathbb{C}$  is said to be **analytic (or holomorphic)** on an open subset  $D \subset \mathbb{C}$  if  $f'(z)$  exists for all  $z \in D$ . An analytic function  $f$  on  $\mathbb{C}$  is said to be **entire**.

**8.1. Cauchy Riemann Equations in Cartesian Coordinates.** If  $f(z)$  is complex differentiable, then by the chain rule

$$\begin{aligned} \partial_x f(x + iy) &= f'(x + iy) \text{ while} \\ \partial_y f(x + iy) &= if'(x + iy). \end{aligned}$$

So in order for  $f(z)$  to be complex differentiable at  $z = x + iy$  we must have

$$(8.1) \quad f_y(x + iy) := \partial_y f(x + iy) = i\partial_x f(x + iy) = if_x(x + iy).$$

Writing  $f = u + iv$ , Eq. (8.1) is equivalent to  $u_y + iv_y = i(u_x + iv_x)$  and thus equivalent to

$$(8.2) \quad u_y = -v_x \text{ and } u_x = v_y.$$

**Theorem 8.2** (Cauchy Riemann Equations). *Suppose  $f(z)$  is a complex function. If  $f'(z)$  exists then  $f_x(z)$  and  $f_y(z)$  exists and satisfy Eq. (8.1), i.e.*

$$\partial_y f(z) = i\partial_x f(z)$$

*Conversely if  $f_x$  and  $f_y$  exists and are continuous in a neighborhood of  $z$ , then  $f'(z)$  exists iff Eq. (8.1) holds.*

**Proof.** (I never got around to giving this proof.) We have already proved the first part of the theorem. So now suppose that  $f_x$  and  $f_y$  exists and are continuous in a neighborhood of  $z$  and Eq. (8.1) holds. To simplify notation let us suppose that  $z = 0$  and  $\Delta z = x + iy$ , then

$$\begin{aligned} f(x + iy) - f(0) &= f(x + iy) - f(x) + f(x) - f(0) \\ &= \int_0^1 \frac{d}{dt} f(x + ity) dt + \int_0^1 \frac{d}{dt} f(tx) dt \\ &= \int_0^1 [yf_y(x + ity) + xf_x(tx)] dt \\ &= \int_0^1 [iyf_x(x + ity) + xf_x(tx)] dt \\ &= \int_0^1 [iy(f_x(x + ity) - f_x(0)) + x(f_x(tx) - f_x(0)) + f_x(0)(x + iy)] dt \\ &= zf_x(0) + \int_0^1 [iy(f_x(x + ity) - f_x(0)) + x(f_x(tx) - f_x(0))] dt \\ &= zf_x(0) + \int_0^1 [iy\varepsilon(z) + x\varepsilon(z)] dt = zf_x(0) + |z|\varepsilon(|z|). \end{aligned}$$

■

**Fact 8.3** (Amazing Fact). We we will eventually show, that if  $f$  is analytic on an open subset  $D \subset \mathbb{C}$ , then  $f$  is infinitely complex differentiable on  $D$ , i.e.  $f$  analytic implies  $f'$  is analytic!!! **Note well:** it is important that  $D$  is open here. See Remark 8.6 below.

**Example 8.4.** Consider the following functions:

- (1)  $f(z) = x + iby$ . In this case  $f_x = 1$  while  $f_y = ib$  so  $f_y = if_x$  iff  $b = 1$ . In this case  $f(z) = z$ .
- (2)  $f(z) = z^2$ , then  $u = x^2 - y^2$  and  $v = 2xy$ ,  $u_y = -2y = -v_x$  and  $v_y = 2x = u_x$ , which shows that  $f(z) = z^2$  is complex differentiable.
- (3)  $f(z) = e^z = e^x(\cos y + i \sin y)$ , so  $f_x = f$  while

$$f_y = e^{ix}(-\sin y + i \cos y) = if = if_x$$

which again shows that  $f$  is complex differentiable.

- (4) Also work out the example  $f(z) = 1/z = \frac{x-iy}{x^2+y^2}$ ,

$$f_x = \frac{x^2 + y^2 - 2x(x-iy)}{(x^2 + y^2)^2} = \frac{y^2 - x^2 + 2ixy}{|z|^4}$$

Note

$$\begin{aligned} -\left(\frac{1}{z}\right)^2 &= -\frac{(x-iy)^2}{(x^2+y^2)^2} = -\frac{x^2 - y^2 - 2ixy}{(x^2+y^2)^2} \\ &= \frac{y^2 - x^2 + 2ixy}{|z|^4} = f_x. \end{aligned}$$

Similarly

$$f_y = \frac{-i(x^2 + y^2) - 2y(x-iy)}{(x^2 + y^2)^2} = \frac{-ix^2 + iy^2 - 2yx}{(x^2 + y^2)^2} = if_x$$

and all of this together shows that  $f'(z) = -\frac{1}{z^2}$  for  $z \neq 0$ .

**Corollary 8.5.** Suppose that  $f = u + iv$  is complex differentiable in an open set  $D$ , then  $u$  and  $v$  are harmonic functions, i.e. that real and imaginary parts of analytic functions are harmonic.

**Proof.** The C.R. equations state that  $v_y = u_x$  and  $v_x = -u_y$ , therefore

$$v_{yy} = u_{xy} = u_{yx} = -v_{xx}.$$

A similar computation works for  $u$ . ■

*Remark 8.6.* The only harmonic functions  $f : \mathbb{R} \rightarrow \mathbb{R}$  are straight lines, i.e.  $f(x) = ax + b$ . In particular, any harmonic function  $f : \mathbb{R} \rightarrow \mathbb{R}$  is infinitely differentiable. This should shed a little light on the Amazing Fact in Example 8.3.

**Example 8.7** (The need for continuity in Theorem 8.2). Exercise 6, on p. 69. Consider the function

$$f(z) = \begin{cases} \frac{\bar{z}^2}{z} & \text{if } z \neq 0 \\ 0 & \text{if } z = 0. \end{cases}$$

Then

$$f_x(0) = \lim_{x \rightarrow 0} \frac{f(x) - f(0)}{x} = \lim_{x \rightarrow 0} \frac{x}{x} = 1$$

while

$$f_y(0) = \lim_{y \rightarrow 0} \frac{f(iy) - f(0)}{y} = \lim_{y \rightarrow 0} \frac{-y^2/iy}{y} = -\frac{1}{i} = i = if_x(0).$$

Thus the Cauchy Riemann equations hold at 0. However,

$$f'(0) = \lim_{z \rightarrow 0} \frac{f(z) - f(0)}{z} = \lim_{z \rightarrow 0} \frac{\bar{z}^2}{z^2}$$



does not exist. For example taking  $z = x$  real and  $z = xe^{i\pi/4}$  we get

$$\lim_{z=x \rightarrow 0} \frac{\bar{z}^2}{z^2} = 1 \text{ while } \lim_{z=xe^{i\pi/4} \rightarrow 0} \frac{\bar{z}^2}{z^2} = \lim_{z=xe^{i\pi/4} \rightarrow 0} \frac{-ix^2}{ix^2} = -1.$$

## 9. (10/15/2003) LECTURE 9

**Example 9.1.** Show  $\operatorname{Re} f$  and  $\operatorname{Im} f$  are harmonic when  $f(z) = z^2$  and  $f(z) = e^z$ .

**Definition 9.2.** A function  $f : D \rightarrow \mathbb{C}$  is **analytic on an open set**  $D$  iff  $f'(z)$  is complex differentiable at all points  $z \in D$ .

**Definition 9.3.** For  $z \neq 0$ , let  $\log z = \{w \in \mathbb{C} : e^w = z\}$ .

Writing  $z = |z|e^{i\theta}$  we and  $w = x + iy$ , we must have  $|z|e^{i\theta} = e^x e^{iy}$  and this implies that  $x = \ln |z|$  and  $y = \theta + 2\pi n$  for some  $n$ . Therefore

$$\log z = \ln |z| + i \arg z.$$

**Definition 9.4.**  $\operatorname{Log}(z) = \ln |z| + i \operatorname{Arg}(z)$ , so  $\operatorname{Log}(re^{i\theta}) = \ln r + i\theta$  if  $r > 0$  and  $-\pi < \theta \leq \pi$ . Note this function is **discontinuous** at points  $z$  where  $\operatorname{Arg}(z) = \pi$ .

**Definition 9.5.** Given a multi-valued function  $f : D \rightarrow \mathbb{C}$ , we say a  $F : D_0 \subset D \rightarrow \mathbb{C}$  is a branch of  $f$  if  $F(z) \in f(z)$  for all  $z \in D_0$  and  $F$  is continuous on  $D_0$ . Here  $D_0$  is taken to be an open subset of  $D$ .

**Example 9.6** (A branch of  $\log(z)$ : a new analytic function). A branch of  $\log(z)$ . Here we take  $D = \{z = x + iy : x > 0\}$ .

$$f(z) = \operatorname{Log}(z) = \frac{1}{2} \ln(x^2 + y^2) + i \tan^{-1}(y/x).$$

Recall that  $\frac{d}{dt} \tan^{-1}(t) = \frac{1}{t^2+1}$  so we learn

$$\begin{aligned} f_x &= \frac{1}{2} \frac{2x}{x^2 + y^2} + i \frac{-\frac{y}{x^2}}{1 + (y/x)^2} = \frac{x}{x^2 + y^2} - i \frac{y}{x^2 + y^2} = \frac{1}{|z|^2} \bar{z} = \frac{1}{z} \\ f_y &= \frac{1}{2} \frac{2y}{x^2 + y^2} + i \frac{\frac{1}{x}}{1 + (y/x)^2} = \frac{y}{x^2 + y^2} + i \frac{x}{x^2 + y^2} = i \frac{1}{z} = i f_x \end{aligned}$$

from which it follows that  $f$  is complex differentiable and  $f'(z) = \frac{1}{z}$ .

Note that for  $\operatorname{Im} z > 0$ , we have  $\operatorname{Log}(z) = f\left(\frac{1}{i}z\right) + i\pi/2$  which shows  $\operatorname{Log}(z)$  is complex differentiable for  $\operatorname{Im} z > 0$ .

Similarly, if  $\operatorname{Im} z < 0$ , we have  $\operatorname{Log}(z) = f(iz) - i\pi/2$  which shows  $\operatorname{Log}(z)$  is complex differentiable for  $\operatorname{Im} z < 0$ .

Combining these remarks shows that  $\operatorname{Log}(z)$  is complex differentiable on  $\mathbb{C} \setminus (-\infty, 0]$ .

**Example 9.7** (Homework Problem: Problem 7a on p.74). Suppose that  $f$  is a complex differentiable function such that  $\operatorname{Im} f = 0$ . Then  $f_x$  and  $f_y$  are real and  $f_y = if_x$  can happen iff  $f_x = f_y = 0$ . But this implies that  $f$  is constant.

**Example 9.8** (Problem 7b on p.74 in class!). Now suppose that  $|f(z)| = c \neq 0$  for all  $z$  is a domain  $D$ . Then

$$\overline{f(z)} = \frac{|f(z)|^2}{f(z)} = \frac{c^2}{f(z)}$$

which shows  $\bar{f}$  is complex differentiable and from this it follows that  $\operatorname{Re} f = \frac{f+\bar{f}}{2}$  and  $\operatorname{Im} f = \frac{f-\bar{f}}{2i}$  are real valued complex differentiable functions. So by the previous example, both  $\operatorname{Re} f$  and  $\operatorname{Im} f$  are constant and hence  $f$  is constant.

**Test #1 was on 10/17/03. This would have been lecture 10.**

## 10. (10/20/2003) LECTURE 10

**Definition 10.1** (Analytic Functions). A function  $f : D \rightarrow \mathbb{C}$  is said to be **analytic** (or **holomorphic**) on an open subset  $D \subset \mathbb{C}$  if  $f'(z)$  exists for all  $z \in D$ .

**Proposition 10.2.** Let  $f = u + iv$  be complex differentiable, and suppose the level curves  $u = a$  and  $v = b$  cross at a point  $z_0$  where  $f'(z_0) \neq 0$  then they cross at a right angle.

**Proof.** The normals to the level curves are given by  $\nabla u$  and  $\nabla v$ , so it suffices to observe from the Cauchy Riemann equations that

$$\nabla u \cdot \nabla v = u_x v_x + u_y v_y = v_y v_x + (-v_x) v_y = 0.$$

**Draw Picture.**

**Alternatively:** Parametrize  $u = a$  and  $v = b$  by  $z(t)$  and  $w(t)$  so that  $z(0) = z_0 = w(0)$ . Then  $f(z(t)) = a + iv(z(t))$  and  $f(w(t)) = u(w(t)) + ib$  and

$$i\beta = \frac{d}{dt} \Big|_0 f(z(t)) = f'(z_0) \dot{z}(0) \text{ while}$$

$$\alpha = \frac{d}{dt} \Big|_0 f(w(t)) = f'(z_0) \dot{w}(0)$$

where  $\alpha = \frac{d}{dt} \Big|_0 u(w(t))$  and  $\beta = \frac{d}{dt} \Big|_0 v(z(t))$ . Therefore

$$\operatorname{Re} \left[ \dot{z}(0) \overline{\dot{w}(0)} \right] = \operatorname{Re} \left[ \frac{i\beta}{f'(z_0)} \frac{\alpha}{f'(z_0)} \right] = 0.$$

Alternatively,

$$\nabla u \cdot \nabla v = u_x v_x + u_y v_y = v_y v_x + (-v_x) v_y = 0.$$

■

**Example 10.3** (Trivial case).

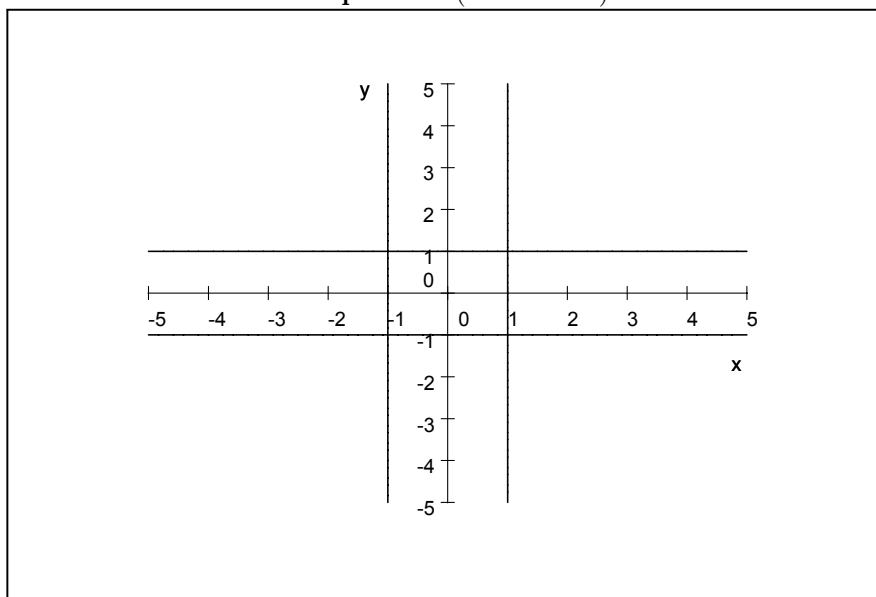

Some Level curves of  $\operatorname{Re} f$  and  $\operatorname{Im} f$  for  $f(z) = z$ .

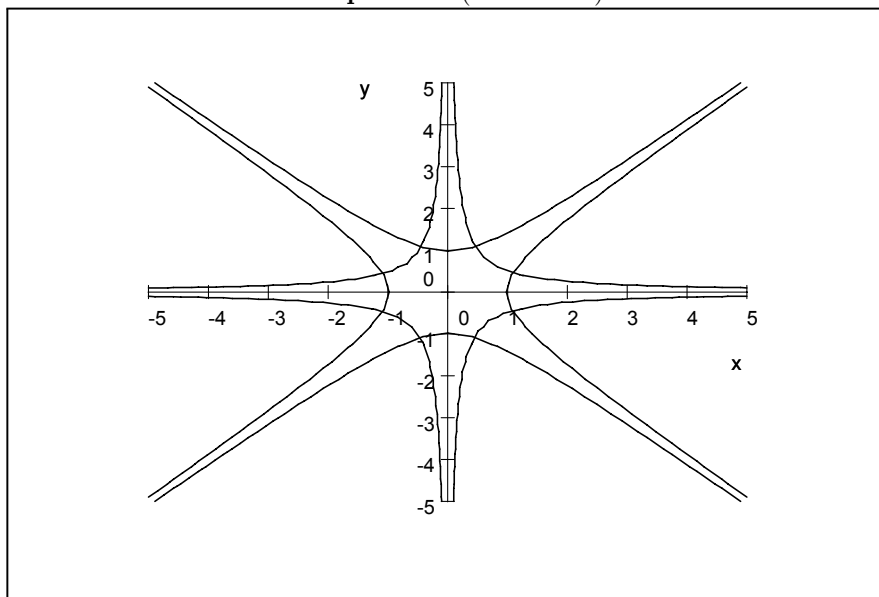
**Example 10.4** (Homework).Some Level curves of  $\operatorname{Re} f$  and  $\operatorname{Im} f$  for  $f(z) = z^2$ .**10.1. Harmonic Conjugates.**

**Definition 10.5.** Given a harmonic function  $u$  on a domain  $D \subset \mathbb{C}$ , we say  $v$  is a harmonic conjugate to  $u$  if  $v$  is harmonic and  $u$  and  $v$  satisfy the C.R. equations.

Notice that  $v$  is uniquely determined up to a constant since if  $w$  is another harmonic conjugate we must have

$$w_y = u_x = v_y \text{ and } w_x = -u_y = v_x.$$

Therefore  $\frac{d}{dt}w(z(t)) = \frac{d}{dt}v(z(t))$  for all paths  $z$  in  $D$  and hence  $w = v + C$  on  $D$ .

**Proposition 10.6.**  $f = u + iv$  is complex analytic on  $D$  iff  $u$  and  $v$  are harmonic conjugates.

**Example 10.7.** Suppose  $u(x, y) = x^2 - y^2$  we wish to find a harmonic conjugate. For this we use

$$\begin{aligned} v_y = u_x &= 2x \text{ and} \\ v_x = -u_y &= 2y \end{aligned}$$

to conclude that  $v = 2xy + C(x)$  and then  $2y = v_x = 2y + C'(x)$  which implies  $C'(x) = 0$  and so  $C = \text{const}$ . Thus we find

$$f = u + iv = x^2 - y^2 + i2xy + iC = z^2 + iC$$

is analytic.

**Example 10.8.** Now suppose that  $u = 2xy$ . In this case we have

$$\begin{aligned} v_y = u_x &= 2y \text{ and} \\ v_x = -u_y &= -2x \end{aligned}$$

and so  $v = \frac{y^2}{2} + C(x)$  and so  $-2x = v_x = C'(x)$  from which we learn that  $C(x) = -x^2 + k$ . Thus we find

$$f = 2xy + i(y^2 - x^2) + ik = -iz^2 + ik$$

is complex analytic.

Recall the following definitions:

**Definition 10.9.** For  $z \neq 0$ , let  $\log z = \{w \in \mathbb{C} : e^w = z\}$ .

Writing  $z = |z|e^{i\theta}$  we and  $w = x + iy$ , we must have  $|z|e^{i\theta} = e^x e^{iy}$  and this implies that  $x = \ln |z|$  and  $y = \theta + 2\pi n$  for some  $n$ . Therefore

$$\log z = \ln |z| + i \arg z.$$

**Definition 10.10.**  $\text{Log}(z) = \ln |z| + i \text{Arg}(z)$ , so  $\text{Log}(re^{i\theta}) = \ln r + i\theta$  if  $r > 0$  and  $-\pi < \theta \leq \pi$ . Note this function is **discontinuous** at points  $z$  where  $\text{Arg}(z) = \pi$ .

**Example 10.11.** Find  $\log 1$ ,  $\log i$ ,  $\log(-1 - \sqrt{3}i)$ .

**Theorem 10.12** (Converse Chain Rule: Optional). *Suppose  $f : D \subset_o \mathbb{C} \rightarrow U \subset_o \mathbb{C}$  and  $g : U \subset_o \mathbb{C} \rightarrow \mathbb{C}$  are functions such that  $f$  is continuous,  $g$  is analytic and  $h := g \circ f$  is analytic, then  $f$  is analytic on the set  $D \setminus \{z : g'(f(z)) = 0\}$ . Moreover  $f'(z) = h'(z)/g'(f(z))$  when  $z \in D$  and  $g'(f(z)) \neq 0$ .*

**Proof.** Suppose that  $z \in D$  and  $g'(f(z)) \neq 0$ . Let  $\Delta f = f(z + \Delta z) - f(z)$  and notice that  $\Delta f = \varepsilon(\Delta z)$  because  $f$  is continuous at  $z$ . On one hand

$$h(z + \Delta z) = h(z) + (h'(z) + \varepsilon(\Delta z))\Delta z$$

while on the other

$$\begin{aligned} h(z + \Delta z) &= g(f(z + \Delta z)) = g(f(z) + \Delta f) \\ &= g(f(z)) + [g'(f(z) + \varepsilon(\Delta f))]\Delta f \\ &= h(z) + [g'(f(z) + \varepsilon(\Delta z))]\Delta f. \end{aligned}$$

Comparing these two equations implies that

$$(10.1) \quad (h'(z) + \varepsilon(\Delta z))\Delta z = [g'(f(z) + \varepsilon(\Delta z))]\Delta f$$

and since  $g'(f(z)) \neq 0$  we may conclude that

$$\frac{\Delta f}{\Delta z} = \frac{h'(z) + \varepsilon(\Delta z)}{g'(f(z) + \varepsilon(\Delta z))} \rightarrow \frac{h'(z)}{g'(f(z))} \text{ as } \Delta z \rightarrow 0,$$

i.e.  $f'(z)$  exists and  $f'(z) = \frac{h'(z)}{g'(f(z))}$ . ■

**Definition 10.13** (Inverse Functions). Given a function  $f : \mathbb{C} \rightarrow \mathbb{C}$  we let  $f^{-1}(w) := \{z \in \mathbb{C} : f(z) = w\}$ . In general this is a multivalued function and we will have to choose a branch when we need an honest function.

**Example 10.14.** Since  $e^{\text{Log}(z)} = z$  and  $\text{Log}(z)$  is continuous on  $D := \mathbb{C} \setminus (-\infty, 0]$ ,  $\text{Log}(z)$  is complex analytic on  $D$  and

$$1 = \frac{d}{dz} z = \frac{d}{dz} e^{\text{Log}(z)} = e^{\text{Log}(z)} \frac{d}{dz} \text{Log}(z) = z \frac{d}{dz} \text{Log}(z),$$

i.e. we have

$$\frac{d}{dz} \text{Log}(z) = \frac{1}{z}.$$

## 11. (10/22/2003) LECTURE 11

**Example 11.1.** In fact the above example generalizes, suppose  $\ell(z)$  is any branch of  $\log(z)$ , that is  $\ell$  is a continuous function on an open set  $D \subset \mathbb{C}$  such that  $e^{\ell(z)} = z$ , then  $\ell'(z) = 1/z$ . Indeed, this follows just as above using the converse to the chain rule.

- Give the proof of Theorem 10.12.

**Lemma 11.2.** *The following properties of  $\log$  hold.*

- (1)  $e^{\log z} = z$
- (2)  $\log e^z = z + i2\pi\mathbb{Z}$
- (3)  $z^n = e^{n \log(z)} = e^{\log z + \log z + \cdots + \log z}$  ( $n$  - times.)
- (4)  $z^{1/n} = e^{\frac{1}{n} \log z}$
- (5)  $\log z^{\pm 1/n} = \pm \frac{1}{n} \log z$  but be careful:
- (6)  $\log z^n \neq n \log z$
- (7)  $\log(wz) = \log w + \log z$  and in particular

$$\log z^n = \overbrace{\log z + \log z + \cdots + \log z}^{n \text{ - times}}.$$

**Proof.**

- (1) This is by definition.
- (2)  $\log e^z = \log e^{z+i2\pi\mathbb{Z}} = x + i(y + 2\pi\mathbb{Z}) = z + i2\pi\mathbb{Z}$ .
- (3) If  $z = re^{i\theta}$ , then  $z^n = r^n e^{in\theta}$  for any  $\theta \in \arg z$ , therefore

$$z^n = r^n e^{in \arg(z)} = e^{n \ln r} e^{in \arg(z)} = e^{n \log z}.$$

Better proof, if  $w \in \log z$ , then  $z = e^w$  so that  $z^n = e^{nw}$  for any  $w \in \log z$ , so  $z^n = e^{n \log(z)}$ .

- (4) We know

$$z^{1/n} = |z|^{1/n} e^{i \frac{1}{n} \arg z} = e^{\frac{1}{n} \ln |z|} e^{i \frac{1}{n} \arg z} = e^{\frac{1}{n} \log z}.$$

- (5) Now

$$\log z^{\pm 1/n} = \ln \left( |z|^{1/n} \right) \pm i \frac{1}{n} \arg z + i2\pi\mathbb{Z} = \ln \left( |z|^{1/n} \right) \pm i \frac{1}{n} \arg z = \pm \frac{1}{n} \log z.$$

- (6) On the other hand if  $z = |z| e^{i\theta}$ , then

$$\log z^n = \ln |z|^n + i \arg(z^n) = n \ln |z| + i(n\theta + 2\pi\mathbb{Z}) = n \ln |z| + in\theta + i2\pi\mathbb{Z}$$

while

$$n \log z = n(\ln |z| + i\theta + i2\pi\mathbb{Z}) = n \ln |z| + in\theta + i2\pi n\mathbb{Z}.$$

- (7) This follows from the corresponding property  $\arg(wz)$  and for  $\ln$ ,

$$\log(wz) = \ln |wz| + i \arg(wz) = \ln |w| + \ln |z| + i[\arg(w) + \arg(z)] = \log w + \log z.$$

■

**Definition 11.3.** For  $c \in \mathbb{C}$ , let  $z^c := e^{c \log z}$ .

As an example let us work out  $i^i$ :

$$i^i = e^{i \log i} = e^{ii(\pi/2+n2\pi)} = e^{-(\pi/2+n2\pi)}.$$

**Example 11.4.** Let  $\ell$  be a **branch of**  $\log(z)$ , i.e. a continuous choice  $\ell : D \rightarrow \mathbb{C}$  such that  $\ell(z) \in \log(z)$  for all  $z \in D$  then we define

$$\begin{aligned} \frac{d}{dz} z_\ell^c &= \frac{d}{dz} e^{c\ell(z)} = e^{c\ell(z)} c\ell'(z) \\ &= ce^{c\ell(z)} \frac{1}{z} = ce^{c\ell(z)} e^{-\ell(z)} = ce^{(c-1)\ell(z)} = cz_\ell^{c-1}. \end{aligned}$$

The book writes  $P.V.z^c = z_+^c := z_{\text{Log}}^c := e^{c\text{Log}(z)}$  for the **principal value** choice. Note with these definitions we have

$$z_\ell^{-c} = e^{-c\ell(z)} = \frac{1}{e^{c\ell(z)}} = \frac{1}{z_\ell^c}.$$

and when  $n \in \mathbb{N}$ , then

$$(z_\ell^c)^n = e^{nc\text{Log}(z)} = z_\ell^{nc}$$

however

$$(z_{\text{Log}}^c)_{\text{Log}}^d = \left( e^{c\text{Log}(z)} \right)_{\text{Log}}^d = e^{d\text{Log}(e^{c\text{Log}(z)})} = e^{d(c\text{Log}(z) + 2\pi in)} = z_{\text{Log}}^{dc} e^{i2\pi nd}$$

for some integer  $n$ .

**Definition 11.5** (Trig. and Hyperbolic Trig. functions:).

$$\begin{aligned} \sin(z) &:= \frac{e^{iz} - e^{-iz}}{2i} \\ \cos(z) &:= \frac{e^{iz} + e^{-iz}}{2} \\ \tan(z) &= \frac{\sin(z)}{\cos(z)} = -i \frac{e^{iz} - e^{-iz}}{e^{iz} + e^{-iz}} \\ \sinh(z) &:= \frac{e^z - e^{-z}}{2} \\ \cosh(z) &:= \frac{e^z + e^{-z}}{2} \\ \tanh(z) &= \frac{\sinh(z)}{\cosh(z)} = \frac{e^z - e^{-z}}{e^z + e^{-z}}. \end{aligned}$$

**Example 11.6.** Basic properties of Trig. functions.

- (1)  $\frac{d}{dz} \sin z = \cos z$  and  $\frac{d}{dz} \sinh z = \cosh z$
- (2)  $\frac{d}{dz} \cos z = -\sin z$  and  $\frac{d}{dz} \cosh z = \sinh z$
- (3)  $\sin z = -i \sinh(iz)$  or  $\sin iz = -i \sinh(iiz) = -i \sinh(-z)$ , i.e.

$$\sin iz = i \sinh z.$$

Alternatively

$$\sin iz = \frac{e^{iiz} - e^{-iiz}}{2i} = -\frac{e^z - e^{-z}}{2i} = i \sinh z.$$

- (4)  $\cos z = \cosh(iz)$  or  $\cosh(z) = \cos(iz)$ .
- (5) All the usual identities hold. For example

$$(11.1) \quad \cos(w+z) = \cos w \cos z - \sin w \sin z$$

$$(11.2) \quad \sin(w+z) = \sin w \cos z + \cos w \sin z.$$

Indeed,

$$\begin{aligned}\cos w \cos z - \sin w \sin z &= \frac{e^{iw} + e^{-iw}}{2} \frac{e^{iz} + e^{-iz}}{2} - \frac{e^{iw} - e^{-iw}}{2i} \frac{e^{iz} - e^{-iz}}{2i} \\ &= \frac{1}{4} \left[ 2e^{i(w+z)} + 2e^{-i(w+z)} \right] = \cos(w+z)\end{aligned}$$

and (this one is homework)

$$\begin{aligned}\sin w \cos z + \cos w \sin z &= \frac{e^{iw} - e^{-iw}}{2i} \frac{e^{iz} + e^{-iz}}{2} + \frac{e^{iw} + e^{-iw}}{2} \frac{e^{iz} - e^{-iz}}{2i} \\ &= \frac{1}{4i} \left[ 2e^{i(w+z)} - 2e^{-i(w+z)} \right] = \sin(w+z).\end{aligned}$$

(6) In particular we have

$$(11.3) \quad \cos(x+iy) = \cos x \cosh y - i \sin x \sinh y$$

$$(11.4) \quad \sin(x+iy) = \sin x \cosh y + i \cos x \sinh y.$$

Indeed,

$$\begin{aligned}\cos(x+iy) &= \cos x \cos iy - \sin x \sin iy \\ &= \cos x \cosh y - i \sin x \sinh y\end{aligned}$$

and

$$\begin{aligned}\sin(x+iy) &= \sin x \cos iy + \cos x \sin iy \\ &= \sin x \cosh y + i \cos x \sinh y.\end{aligned}$$



12. (10/24/2003) LECTURE 12

Remark 12.1 (Roots Remarks).

- (1) **Warning:**  $1^i = e^{i \log 1} = e^{i(i2\pi\mathbb{Z})} = \{1, e^{\pm 2\pi}, e^{\pm 4\pi}, \dots\} \neq 1$
- (2)  $i^i = e^{i \log i} = e^{ii(\pi/2+n2\pi)} = e^{-(\pi/2+n2\pi)} = e^{-\pi/2} \{1, e^{\pm 2\pi}, e^{\pm 4\pi}, \dots\}$ .
- (3) On the positive side we do have  $(w^2 z)^{1/2} = wz^{1/2}$  or more generally that

$$(w^n z)^{1/n} = wz^{1/n}$$

for any integer  $n$ . To prove this,  $\xi \in (w^n z)^{1/n}$  iff  $\xi^n = w^n z$  iff  $\left(\frac{\xi}{w}\right)^n = z$  iff  $\frac{\xi}{w} \in z^{1/n}$  iff  $\xi \in wz^{1/n}$ .

**Alternatively,**

$$(w^2 z)^{1/2} = e^{\frac{1}{2} \log(w^2 z)} = e^{\frac{1}{2} [\log(z) + \log(w^2)]} = e^{\frac{1}{2} \log(z)} e^{\frac{1}{2} \log(w^2)} = z^{1/2} e^{\frac{1}{2} \log(w^2)}.$$

Now if  $w = re^{i\theta}$ , then

$$\log w^2 = 2 \ln r + i(2\theta + 2\pi\mathbb{Z})$$

and therefore,

$$e^{\frac{1}{2} \log w^2} = e^{[\ln r + i(\theta + \pi\mathbb{Z})]} = \pm r e^{i\theta} = \pm w.$$

But  $\pm wz^{1/2} = z^{1/2}$ .

- (4)  $\log z^{1/2} = \frac{1}{2} \log z$ . Indeed,

$$\log z^{1/2} = \log \left( e^{\frac{1}{2} [\ln|z| + i \arg z]} \right) = \frac{1}{2} [\ln|z| + i \arg z] + i2\pi\mathbb{Z} = \frac{1}{2} [\ln|z| + i \arg z] = \frac{1}{2} \log z.$$

**Example 12.2.** Continuing Example 11.6 above.

- (1)

$$\sin^2 z + \cos^2 z = \left[ \frac{e^{iz} - e^{-iz}}{2i} \right]^2 + \left[ \frac{e^{iz} + e^{-iz}}{2} \right]^2 = \frac{1}{4} = 1.$$

- (2) Taking  $w = x$  and  $z = iy$  in the above equations shows

$$\begin{aligned} \cos z &= \cos x \cos iy - \sin x \sin iy \\ &= \cos x \cosh y - i \sin x \sinh y \end{aligned}$$

and

$$\begin{aligned} \sin z &= \sin x \cos iy + \cos x \sin iy \\ &= \sin x \cosh y + i \cos x \sinh y \end{aligned}$$

- (3) From this it follows that  $\sin z = 0$  iff  $\sin x \cosh y = 0$  and  $\cos x \sinh y = 0$ . Since,  $\cosh y$  is never zero we must have  $\sin x = 0$  in which case  $\cos x \neq 0$  so that  $\sinh y = 0$  i.e.  $y = 0$ . So the only solutions to  $\sin z = 0$  happen when  $z$  is real and hence  $z = \pi\mathbb{Z}$ . A similar argument works for  $\cos z$ .
- (4) Lets find all the roots of  $\sin z = 2$ ,

$$2 = \sin z = \sin x \cosh y + i \cos x \sinh y$$

and so

$$\cos x \sinh y = 0 \text{ and } \sin x \cosh y = 2.$$

Hence either  $y = 0$  and  $\sin x = 2$  which is impossible of  $\cos x = 0$ , i.e.  $x = \frac{\pi}{2} + n\pi$  for some integer  $n$ , and in this case  $\sin x = (-1)^n$  and we must have  $(-1)^n \cosh y = 2$  which can happen only for **even**  $n$ . Now  $\cosh y = 2$

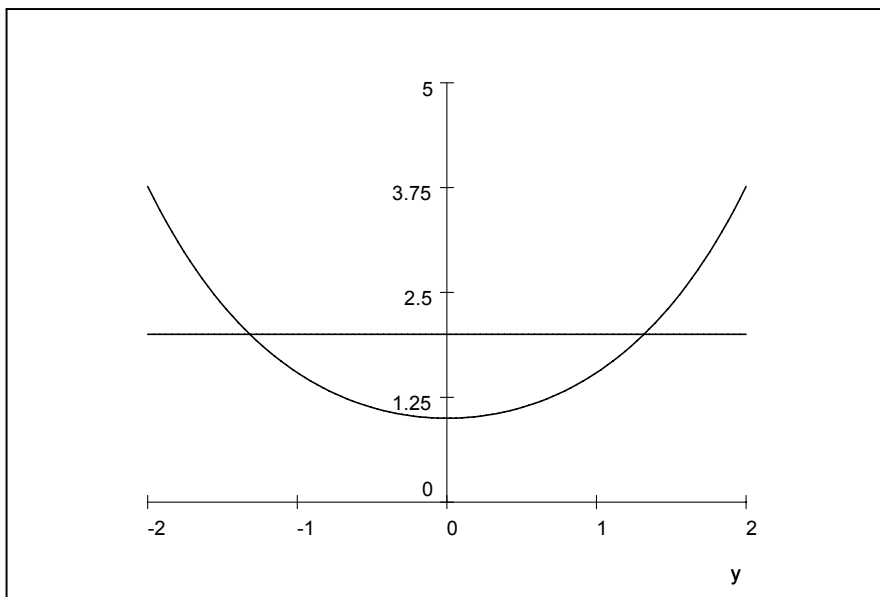

Finding the roots of  $\cosh y = 2$  graphically.

iff (with  $\xi = e^y$ )  $2 = \frac{\xi + \xi^{-1}}{2}$ , i.e.

$$\xi^2 + 1 - 4\xi = 0$$

or

$$\xi = \frac{4 \pm \sqrt{16 - 4}}{2} = 2 \pm \sqrt{4 - 1} = 2 \pm \sqrt{3}.$$

Therefore  $y = \ln(2 \pm \sqrt{3})$  and we have

$$(12.1) \quad \sin z = 2 \text{ iff } z = \frac{\pi}{2} + 2n\pi + i \ln(2 \pm \sqrt{3}) \text{ for some } n \in \mathbb{Z}.$$

It should be noted that

$$(2 + \sqrt{3})(2 - \sqrt{3}) = 4 - 3 = 1$$

so that the previous equation may be written as

$$z = \frac{\pi}{2} + 2n\pi \pm i \ln(2 + \sqrt{3}).$$

**Theorem 12.3.** *The inverse trig. functions*

$$\sin^{-1}(z) = -i \log \left( iz + (1 - z^2)^{1/2} \right)$$

$$\cos^{-1}(z) = -i \log \left( z + i(1 - z^2)^{1/2} \right)$$

$$\tan^{-1}(z) = \frac{i}{2} \log \left( \frac{i+z}{i-z} \right).$$

Moreover we have

$$\begin{aligned}\frac{d}{dz} \sin^{-1}(z) &= \frac{1}{\sqrt{1-z^2}} \\ \frac{d}{dz} \cos^{-1}(z) &= \frac{-1}{\sqrt{1-z^2}} \\ \frac{d}{dz} \tan^{-1}(z) &= \frac{1}{1+z^2}\end{aligned}$$

with appropriate choices of branches being specified.

**Example 12.4.**

$$\cos^{-1}(0) = \frac{1}{i} \log(\pm i) = \frac{1}{i} i \left( \pm \frac{\pi}{2} + 2\pi\mathbb{Z} \right) = \left\{ \pm \frac{\pi}{2}, \pm \frac{3\pi}{2}, \pm \frac{5\pi}{2} \right\}$$

so the zeros of the complex cosine function are precisely the zeros of the real cosine function. Similarly

$$\begin{aligned}\sin^{-1}(2) &= -i \log \left( i2 + (1-4)^{1/2} \right) = -i \log \left( i(2 \pm \sqrt{3}) \right) \\ &= -i \left[ \log i + \log(2 \pm \sqrt{3}) \right] = -i \left[ \frac{\pi}{2} + 2\pi n + \ln(2 \pm \sqrt{3}) \right] \\ &= -i \left[ i \left( \frac{\pi}{2} + 2\pi n \right) + \ln(2 \pm \sqrt{3}) \right] \\ &= \frac{\pi}{2} + 2\pi n - i \ln(2 \pm \sqrt{3}) = \frac{\pi}{2} + 2\pi n \pm i \ln(2 + \sqrt{3})\end{aligned}$$

as before.

**Proof.**

- $\cos^{-1}(w)$  : We have  $z \in \cos^{-1}(w)$  iff

$$w = \cos(z) = \frac{e^{iz} + e^{-iz}}{2} = \frac{\xi + \xi^{-1}}{2}$$

where  $\xi = e^{iz}$ . Thus

$$\xi^2 - 2w\xi + 1 = 0$$

or

$$\xi = \frac{2w + (4w^2 - 4)^{1/2}}{2} = w + (w^2 - 1)^{1/2}$$

and therefore

$$iz = \log \xi = \log \left( w + (w^2 - 1)^{1/2} \right)$$

and we have shown

$$\begin{aligned}\cos^{-1}(w) &= -i \log \left( w + (w^2 - 1)^{1/2} \right) \\ &= -i \log \left( w + i(1 - w^2)^{1/2} \right).\end{aligned}$$

■

## 13. (10/31/2003) LECTURE 13 (CONTOUR INTEGRALS)

Lost two Lectures because of the big fire!!

(Here I only computed  $\frac{d}{dz} \tan^{-1}(z)$  in the proof below.)

**Proof. Continuation of the proof.**

Let us now compute the derivative of this  $\cos^{-1}(z)$ . For this we will need to take a branch of  $f(z)$  of  $\cos^{-1} z$ , say

$$(13.1) \quad f(z) = -i\ell(z + iQ(1 - z^2))$$

where  $\ell$  is a branch of log and  $Q$  is a branch of the square-root. Then  $\cos f(z) = z$  and differentiating this equations gives,  $-\sin f(z) \cdot f'(z) = 1$  or equivalently that

$$f'(z) = \frac{1}{-\sin f(z)} \in -\frac{1}{(1 - z^2)^{1/2}}.$$

since  $\sin f(z) \in (1 - z^2)^{1/2}$ . The question now becomes which branch do we take. To determine this let us differentiate Eq. (13.1);

$$\begin{aligned} f'(z) &= \frac{-i}{z + iQ(1 - z^2)} \left\{ 1 - \frac{i}{2Q(1 - z^2)} (2z) \right\} \\ &= \frac{-i}{z + iQ(1 - z^2)} \left\{ \frac{Q(1 - z^2) - iz}{Q(1 - z^2)} \right\} \\ &= \frac{-1}{z + iQ(1 - z^2)} \left\{ \frac{z + iQ(1 - z^2)}{Q(1 - z^2)} \right\} = \frac{-1}{Q(1 - z^2)} \end{aligned}$$

so we must use the same branch of the square-root used in Eq. (13.1). Hence we have shown

$$\left. \frac{d}{dz} \cos^{-1}(z) = \frac{-1}{\sqrt{1 - z^2}}, \right"$$

with the branch conditions determined as above.

- $\tan^{-1}(w)$ : We have  $z \in \tan^{-1}(w)$  iff

$$w = \tan(z) = -i \frac{e^{iz} - e^{-iz}}{e^{iz} + e^{-iz}} = -i \frac{\xi - \xi^{-1}}{\xi + \xi^{-1}} = -i \frac{\xi^2 - 1}{\xi^2 + 1}$$

where  $\xi = e^{iz}$ . Thus

$$(\xi^2 + 1)w + i(\xi^2 - 1) = 0$$

or

$$\xi^2(w + i) = i - w$$

that is

$$\xi = \left( \frac{i - w}{i + w} \right)^{\frac{1}{2}}$$

and hence

$$iz = \log \xi = \log \left( \frac{i - w}{i + w} \right)^{\frac{1}{2}} = -\frac{1}{2} \log \left( \frac{i + w}{i - w} \right)$$

so that

$$\tan^{-1}(w) = \frac{i}{2} \log \left( \frac{i + w}{i - w} \right).$$

We have used here that  $\log\left(\eta^{-\frac{1}{n}}\right) = -\frac{1}{n}\log\eta$  which happens because  $n$  is an integer, see Lemma 11.2. Let us now compute the derivative of  $\tan^{-1}(w)$ . In order to do this, let  $\ell$  be a branch of  $\log$ , and the  $f(w) = \frac{i}{2}\ell\left(\frac{i+w}{i-w}\right)$  be a Branch of  $\tan^{-1}(w)$ , then

$$\begin{aligned} \frac{d}{dw}f(w) &= \frac{i}{2} \frac{1}{\frac{i+w}{i-w}} \frac{d}{dw} \frac{i+w}{i-w} = \frac{i}{2} \frac{i-w}{i+w} \frac{(i-w) + (i+w)}{(i-w)^2} \\ &= -\frac{1}{(i+w)(i-w)} = \frac{1}{(w+i)(w-i)} = \frac{1}{1+w^2}. \end{aligned}$$

Thus we have

$$\frac{d}{dw} \tan^{-1}(w) = \frac{1}{1+w^2}$$

where the formula is valid for any branch of  $\tan^{-1}(w)$  that we have chosen.

- $\sin^{-1}(w)$  : (This is done in the book so do not do in class.) We have  $z \in \sin^{-1}(w)$  iff

$$w = \sin(z) = \frac{e^{iz} - e^{-iz}}{2i} = \frac{\xi - \xi^{-1}}{2i}$$

where  $\xi = e^{iz}$ . Thus

$$\xi^2 - 1 - 2iw\xi = 0$$

or

$$\xi = \frac{2iw + (-4w^2 + 4)^{1/2}}{2} = iw + (1 - w^2)^{1/2}$$

and therefore

$$iz = \log \xi = \log\left(iw + (1 - w^2)^{1/2}\right)$$

and we have shown

$$\sin^{-1}(w) = -i \log\left(iw + (1 - w^2)^{1/2}\right).$$

Example if  $w = 0$ , we have

$$\sin^{-1}(0) = \frac{1}{i} \log(\pm 1) = \frac{1}{i} i\pi\mathbb{Z} = \pi\mathbb{Z}.$$

Suppose that

$$(13.2) \quad f(w) = -i\ell\left(iw + Q(1 - w^2)\right)$$

where  $\ell$  is a branch of  $\log$  and  $Q$  is a branch of the square-root, then  $\sin f(w) = w$  and so differentiating this equation in  $w$  gives  $\cos f(w) f'(w) = 1$  or equivalently that

$$f'(w) = \frac{1}{\cos f(w)}.$$

Now  $\cos f(w) \in (1-w^2)^{1/2}$ , the question is which branch do we take. To determine this let us differentiate Eq. (13.2). Here we have

$$\begin{aligned} f'(w) &= \frac{-i}{iw + Q(1-w^2)} \left\{ i + \frac{1}{2Q(1-w^2)}(-2w) \right\} \\ &= \frac{1}{iw + Q(1-w^2)} \left\{ 1 + i \frac{w}{Q(1-w^2)} \right\} \\ &= \frac{1}{iw + Q(1-w^2)} \left\{ \frac{iw + Q(1-w^2)}{Q(1-w^2)} \right\} = \frac{1}{Q(1-w^2)} \end{aligned}$$

so we must use the same branch of the square-root used in Eq. (13.2). Hence we have shown

$$\text{“} \frac{d}{dz} \sin^{-1}(z) = \frac{1}{\sqrt{1-z^2}}, \text{”}$$

where one has to be careful about the branches which are used.

■

### 13.1. Complex and Contour integrals:

**Definition 13.1.** A path or contour  $C$  in  $D \subset \mathbb{C}$  is a piecewise  $C^1$  - function  $z : [a, b] \rightarrow \mathbb{C}$ . For a function  $f : D \rightarrow \mathbb{C}$ , we let

$$\int_C f(z) dz = \int_a^b f(z(t)) \dot{z}(t) dt$$

**Example 13.2** (Some Contours). (1)  $z(t) = z_0 + re^{it}$  for  $0 \leq t \leq \pi$  is a semi-circle centered at  $z_0$ .

(2) If  $z_0, z_1 \in \mathbb{C}$  then  $z(t) = z_0(1-t) + z_1t$  for  $0 \leq t \leq 1$  parametrizes the straight line segment going from  $z_0$  to  $z_1$ .

(3) If  $z(t) = t + it^2$  for  $-1 \leq t \leq 1$ , then  $z(t)$  parametrizes part of the parabola  $y = x^2$ . More generally  $z(t) = t + if(t)$  parametrizes the graph,  $y = f(x)$ .

(4)  $z(t) = t + i\sqrt{1-t^2}$  for  $-1 \leq t \leq 1$  parametrizes the semicircle of radius 1 centered at 0 as does  $z(t) = e^{-i\pi t}$  for  $-1 \leq t \leq 0$ .

**Example 13.3.** Integrate  $f(z) = z - 1$  along the two contours

(1)  $C_1 : z = x$  for  $x = 0$  to  $x = 2$  and

(2)  $C_2 : z = 1 + e^{i\theta}$  for  $\pi \leq \theta \leq 2\pi$ .

For the first case we have

$$\int_{C_1} (z-1) dz = \int_0^2 (x-1) dx = \frac{1}{2}(x-1)^2 \Big|_0^2 = 0$$

and for the second

$$\begin{aligned} \int_{C_2} (z-1) dz &= \int_{\pi}^{2\pi} (1 + e^{i\theta} - 1) ie^{i\theta} d\theta \\ &= \int_{\pi}^{2\pi} ie^{i2\theta} d\theta = \frac{i}{2} e^{i2\theta} \Big|_{\pi}^{2\pi} = 0 \end{aligned}$$

**Example 13.4.** Repeat the above example for  $f(z) = \bar{z} - 1$ .

For the first case we have

$$\int_{C_1} (\bar{z} - 1) dz = \int_0^2 (x - 1) dx = \frac{1}{2} (x - 1)^2 \Big|_0^2 = 0$$

and for the second

$$\begin{aligned} \int_{C_2} (\bar{z} - 1) dz &= \int_{\pi}^{2\pi} (1 + e^{-i\theta} - 1) i e^{i\theta} d\theta \\ &= \int_{\pi}^{2\pi} i d\theta = i\pi \neq 0 \end{aligned}$$

**Example 13.5** (I skipped this example.). Here we consider  $f(z) = y - x - i3x^2$  along the contours

- (1)  $C_1$  : consists of the straight line paths from  $0 \rightarrow i$  and  $i \rightarrow 1 + i$  and
- (2)  $C_2$  : consists of the straight line path from  $0 \rightarrow 1 + i$ .

1. For the first case  $z = iy$ ,  $dz = idy$  and  $z = x + i$  and  $dz = dx$ , so

$$\begin{aligned} \int_{C_1} f(z) dz &= \int_0^1 (y - x - i3x^2) \Big|_{x=0} idy + \int_0^1 (y - x - i3x^2) \Big|_{y=1} dx \\ &= i \int_0^1 y dy + \int_0^1 (1 - x - i3x^2) dx \\ &= \frac{i}{2} + \left(1 - \frac{1}{2} - i\right) = \frac{1}{2}(1 - i). \end{aligned}$$

2. For the second contour,  $z = t(1 + i) = t + it$ , then  $dz = (1 + i) dt$ ,

$$\begin{aligned} \int_{C_2} f(z) dz &= \int_0^1 (y - x - i3x^2) \Big|_{x=y=t} (1 + i) dt \\ &= (1 + i) \int_0^1 (t - t - i3t^2) dt \\ &= (1 + i)(-i) = 1 - i. \end{aligned}$$

Notice the answers are different.

**Example 13.6.** Now lets use the same contours but with the function,  $f(z) = z^2$  instead. In this case

$$\begin{aligned} \int_{C_1} z^2 dz &= \int_0^1 (iy)^2 idy + \int_0^1 (x + i)^2 dx \\ &= -i \frac{1}{3} + \frac{1}{3} (x + i)^3 \Big|_0^1 = -i \frac{1}{3} + \frac{1}{3} (1 + i)^3 - \frac{1}{3} i^3 \\ &= \frac{1}{3} (1 + i)^3 \end{aligned}$$

while for the second contour,

$$\int_{C_2} z^2 dz = \int_0^1 t^2 (1 + i)^2 (1 + i) dt = \frac{1}{3} (1 + i)^3.$$

## 14. (11/3/2003) LECTURE 14 (CONTOUR INTEGRALS CONTINUED)

**Proposition 14.1.** *Let us recall some properties of complex integrals*

(1)

$$\int_a^b w(\phi(t)) \dot{\phi}(t) dt = \int_{\phi(a)}^{\phi(b)} w(\tau) d\tau$$

(2) *If  $f(z)$  is continuous in a neighborhood of a contour  $C$ , then  $\int_C f(z) dz$  is independent of how  $C$  is parametrized as long as the orientation is kept the same.*

(3) *If  $-C$  denotes  $C$  traversed in the opposite direction, then*

$$\int_{-C} f(z) dz = - \int_C f(z) dz.$$

**Proof.**

(1) The first fact follows from the change of variable theorem for real variables.

(2) Suppose that  $z : [a, b] \rightarrow \mathbb{C}$  is a parametrization of  $C$ , then other parametrizations of  $C$  are of the form

$$w(s) = z(\phi(s))$$

where  $\phi : [\alpha, \beta] \rightarrow [a, b]$  such that  $\phi(\alpha) = a$  and  $\phi(\beta) = b$ . Hence

$$\int_{\alpha}^{\beta} f(w(s)) w'(s) ds = \int_{\alpha}^{\beta} f(z(\phi(s))) \dot{z}(\phi(s)) \phi'(s) ds$$

and letting  $t = \phi(s)$ , we find

$$\int_{\alpha}^{\beta} f(w(s)) w'(s) ds = \int_a^b f(z(t)) \dot{z}(t) dt$$

as desired.

(3) Suppose that  $z : [0, 1] \rightarrow \mathbb{C}$  is a parametrization of  $C$ , then  $w(s) := z(1-s)$  parametrizes  $-C$ , so that

$$\begin{aligned} \int_{-C} f(z) dz &= - \int_0^1 f(z(1-s)) \dot{z}(1-s) ds = \int_1^0 f(z(t)) \dot{z}(t) dt \\ &= - \int_0^1 f(z(t)) \dot{z}(t) dt = - \int_C f(z) dz, \end{aligned}$$

wherein we made the change of variables,  $t = 1 - s$ .

■

**Theorem 14.2** (Fundamental Theorem of Calculus). *Suppose  $C$  is a contour in  $D$  and  $f : D \rightarrow \mathbb{C}$  is an analytic function, then*

$$\int_C f'(z) dz = f(C_{end}) - f(C_{begin}).$$

**Proof.** Let  $z : [a, b] \rightarrow \mathbb{C}$  parametrize the contour, then

$$\int_C f'(z) dz = \int_a^b f'(z(t)) \dot{z}(t) dt = \int_a^b \frac{d}{dt} f(z(t)) dt = f(z(t)) \Big|_{t=a}^{t=b}.$$

■



**Example 14.3.** Using either of contours in Example 13.5, we again learn (more easily)

$$\int_{C_1} z^2 dz = \frac{1}{3} z^3 |_{\partial C_1} = \frac{1}{3} [(1+i)^3 - (0)^3].$$

**Example 14.4.** Suppose that  $C$  is a closed contour in  $\mathbb{C}$  such which does not pass through 0, then

$$\int_C z^n dz = 0 \text{ if } n \neq -1.$$

The case  $n = 1$  is different and leads to the winding number. This can be computed explicitly, using a branch of a logarithm. For example if  $C : [0, 2\pi] \rightarrow \mathbb{C} \setminus \{0\}$  crosses  $(-\infty, 0)$  only at  $z(0) = z(2\pi)$ , then

$$\begin{aligned} \int_C \frac{1}{z} dz &= \lim_{\varepsilon \downarrow 0} \int_{C_\varepsilon} \frac{1}{z} dz = \lim_{\varepsilon \downarrow 0} [\text{Log}(z(2\pi - \varepsilon)) - \text{Log}(z(\varepsilon))] \\ &= \lim_{\varepsilon \downarrow 0} \left[ \ln \left| \frac{z(2\pi - \varepsilon)}{z(\varepsilon)} \right| + i(2\pi - O(\varepsilon) - O(\varepsilon)) \right] \\ &= i2\pi. \end{aligned}$$

Also work out explicitly the special case where  $C(\theta) = re^{i\theta}$  with  $\theta : 0 \rightarrow 2\pi$ .

**Proposition 14.5.** *Let us recall some estimates of complex integrals*

(1)

$$\left| \int_\alpha^\beta w(t) dt \right| \leq \int_\alpha^\beta |w(t)| dt.$$

(2) *We also have*

$$\left| \int_C f(z) dz \right| \leq \int_C |f(z)| |dz| \leq ML$$

where  $|dz| = |\dot{z}(t)| dt$  and  $M = \sup_{z \in C} |f(z)|$ .

**Proof.**

(1) To prove this let  $\rho \geq 0$  and  $\theta \in \mathbb{R}$  be chosen so that

$$\int_\alpha^\beta w(t) dt = \rho e^{i\theta},$$

then

$$\begin{aligned} \left| \int_\alpha^\beta w(t) dt \right| &= \rho = e^{-i\theta} \int_\alpha^\beta w(t) dt = \int_\alpha^\beta e^{-i\theta} w(t) dt \\ &= \int_\alpha^\beta \text{Re} [e^{-i\theta} w(t)] dt \leq \int_\alpha^\beta |\text{Re} [e^{-i\theta} w(t)]| dt \\ &\leq \int_\alpha^\beta |e^{-i\theta} w(t)| dt = \int_\alpha^\beta |w(t)| dt. \end{aligned}$$

**Alternatively:**

$$\begin{aligned} \left| \int_{\alpha}^{\beta} w(t) dt \right| &= \left| \lim_{\text{mesh} \rightarrow 0} \sum w(c_i)(t_i - t_{i-1}) \right| = \lim_{\text{mesh} \rightarrow 0} \left| \sum w(c_i)(t_i - t_{i-1}) \right| \\ &\leq \lim_{\text{mesh} \rightarrow 0} \sum |w(c_i)|(t_i - t_{i-1}) \quad (\text{by the triangle inequality}) \\ &= \int_{\alpha}^{\beta} |w(t)| dt. \end{aligned}$$

(2) For the last item

$$\begin{aligned} \left| \int_C f(z) dz \right| &= \left| \int_a^b f(z(t)) \dot{z}(t) dt \right| \leq \int_a^b |f(z(t))| |\dot{z}(t)| dt \\ &\leq M \int_a^b |\dot{z}(t)| dt \leq ML \end{aligned}$$

wherein we have used

$$|\dot{z}(t)| dt = \sqrt{[\dot{x}(t)]^2 + [\dot{y}(t)]^2} dt = dl.$$

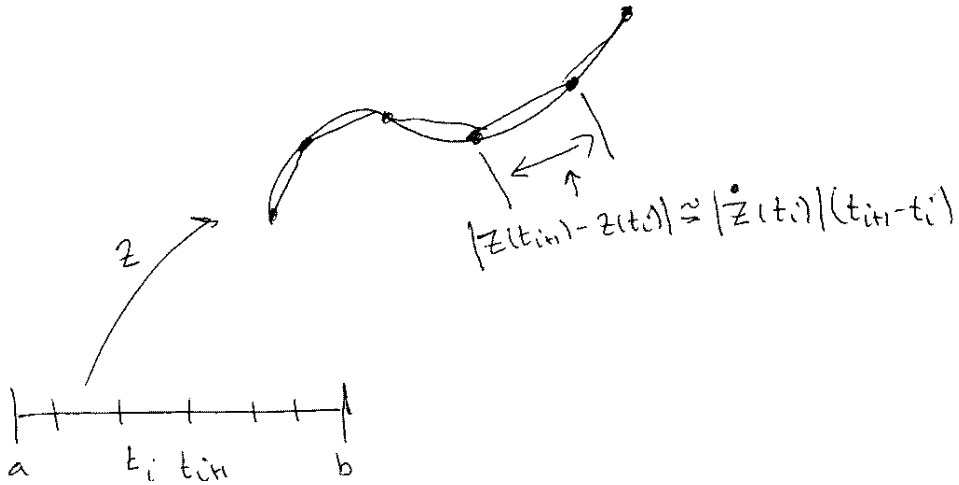

■

## 15. (11/05/2003) LECTURE 15

**Example 15.1.** The goal here is to estimate the integral

$$\left| \int_C \frac{1}{z^4} dz \right|$$

where  $C$  is the contour joining  $i$  to  $1$  by a straight line path. In this case  $M = \frac{1}{|\frac{1}{2}(1+i)|^4}$  and  $L = |1 - i| = \sqrt{2}$  and this gives the estimate

$$\left| \int_C \frac{1}{z^4} dz \right| \leq \sqrt{2} \frac{1}{\left| \frac{1}{\sqrt{2}} \right|^4} = 4\sqrt{2}.$$

**Example 15.2.** Let  $C$  be the contour consisting of straight line paths  $-4 \rightarrow 0$ ,  $0 \rightarrow 3i$  and then  $3i \rightarrow -4$  and we wish to estimate the integral

$$\int_C (e^z - \bar{z}) dz.$$

To do this notice that on  $C$  we have

$$|e^z - \bar{z}| \leq |e^z| + |\bar{z}| \leq e^{\operatorname{Re} z} + |z| \leq e^0 + 4 = 5$$

while

$$\ell(C) = 4 + 3 + |3i - (-4)| = 4 + 3 + \sqrt{3^2 + 4^2} = 3 + 4 + 5 = 12$$

and hence

$$\left| \int_C (e^z - \bar{z}) dz \right| \leq 12 \cdot 5 = 60.$$

**Note:** The material after this point will not be on the second midterm.

**Notation 15.3.** Let  $D \subset_o \mathbb{C}$  and  $\alpha : [a, b] \rightarrow D$  and  $\beta : [a, b] \rightarrow D$  be two piecewise  $C^1$  - contours in  $D$ . Further assume that either  $\alpha(a) = \beta(a)$  and  $\alpha(b) = \beta(b)$  or  $\alpha$  and  $\beta$  are loops. We say  $\alpha$  is **homotopic to**  $\beta$  if there is a continuous map  $\sigma : [a, b] \times [0, 1] \rightarrow D$ , such that  $\sigma(t, 0) = \alpha(t)$ ,  $\sigma(t, 1) = \beta(t)$  and either  $\sigma(a, s) = \alpha(a) = \beta(a)$  and  $\sigma(b, s) = \alpha(b) = \beta(b)$  for all  $s$  or  $t \rightarrow \sigma(t, s)$  is a loop for all  $s$ . Draw lots of pictures here.

**Definition 15.4** (Simply Connected). A connected region  $D \subset_o \mathbb{C}$  is **simply connected** if all closed contours,  $C \subset D$  are homotopic to a constant path.

**Theorem 15.5** (Cauchy Goursat Theorem). *Suppose that  $f : D \rightarrow \mathbb{C}$  is an analytic function and  $\alpha$  and  $\beta$  are two contours in  $D$  which are homotopic relative end-points or homotopic loops in  $D$ , then*

$$\int_{\alpha} f(z) dz = \int_{\beta} f(z) dz.$$

In particular if  $D$  is simply connected, then

$$\int_C f(z) dz = 0$$

for all closed contours in  $D$  and complex analytic functions,  $f$ , on  $D$ .

**Example 15.6.** Suppose  $C$  is a closed contour in  $\mathbb{C}$ , then

- (1)  $\int_C e^{\sin z} dz = 0$  and  $\int_{\alpha} e^{\sin z} dz$  depends only on the endpoints of  $\alpha$ .
- (2)  $\int_C z^n dz = 0$  for all  $n \in \mathbb{N} \cup \{0\}$ .

(3) However if  $C(\theta) = re^{i\theta}$  for  $\theta : 0 \rightarrow 2\pi$ , then

$$\int_C \bar{z} dz = \int_0^{2\pi} re^{-i\theta} i r e^{i\theta} d\theta = 2\pi i r^2 \neq 0.$$

**Example 15.7.** Suppose  $C$  is a closed contour in  $\mathbb{C} \setminus \{0\}$ , then

- (1)  $\int_C e^{\sin z} dz = 0$  and  $\int_\alpha e^{\sin z} dz$  depends only on the endpoints of  $\alpha$ .
- (2) However  $\int_C z^{-1} dz = 2\pi i \neq 0$ .
- (3) On the other hand if  $C$  is a loop in  $\mathbb{C} \setminus (-\infty, 0]$ , then we know

$$\int_C z^{-1} dz = 0$$

this can be checked by direct computation. However it is harder to check directly that

$$\int_C \frac{e^{\sin z}}{z} dz = 0$$

for all closed contours in  $\mathbb{C} \setminus (-\infty, 0]$ .

16. (11/07/2003) LECTURE 16

**Example 16.1** (Fourier Transform). So the example  $\oint_C \frac{1}{z} dz = 2\pi i$  again, where  $C$  is a simple closed counter clockwise oriented contour surrounding 0. Do this by deforming  $C$  to the unit circle contour.

**Example 16.2** (Fourier Transform). The goal here is to compute the integral

$$Z := \int_{-\infty}^{\infty} e^{-\frac{1}{2}x^2} e^{i\lambda x} dx := \lim_{R \rightarrow \infty} \int_{-R}^R e^{-\frac{1}{2}x^2} e^{i\lambda x} dx.$$

We do this by completing the squares,

$$-\frac{1}{2}x^2 + i\lambda x = -\frac{1}{2}(x - i\lambda)^2 - \frac{1}{2}\lambda^2$$

from which we learn

$$Z = e^{-\frac{1}{2}\lambda^2} \lim_{R \rightarrow \infty} \int_{-R}^R e^{-\frac{1}{2}(x-i\lambda)^2} dx = e^{-\frac{1}{2}\lambda^2} \lim_{R \rightarrow \infty} \int_{\Gamma_R} e^{-\frac{1}{2}z^2} dz$$

where  $\Gamma_R(x) := x - i\lambda$  for  $x : -R \rightarrow R$ . We would like to replace the contour  $\Gamma_R$  by  $[-R, R]$ . This can be done using the Cauchy Goursat theorem and the estimates,

$$\left| \int_{\pm R}^{\pm R - i\lambda} e^{-\frac{1}{2}z^2} dz \right| \leq |\lambda| e^{-\frac{1}{2}R^2} \rightarrow 0 \text{ as } R \rightarrow \infty,$$

see Figure 3. Therefore we conclude that

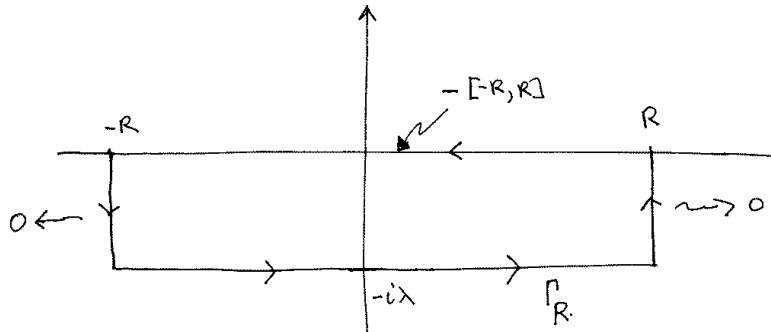

FIGURE 3. By the Cauchy Goursat theorem, the integral of any entire function around the closed contour shown is 0.

$$\int_{-\infty}^{\infty} e^{-\frac{1}{2}x^2} e^{i\lambda x} dx = e^{-\frac{1}{2}\lambda^2} \lim_{R \rightarrow \infty} \int_{-R}^R e^{-\frac{1}{2}x^2} dx = \sqrt{2\pi} e^{-\frac{1}{2}\lambda^2},$$

where the last integral is done by a standard real variable trick and the answer is given by  $\sqrt{2\pi}$ .

**Theorem 16.3** (Cauchy Integral Formula). Suppose that  $f : D \rightarrow \mathbb{C}$  is analytic and  $C \subset D$  is a contour which is homotopic to  $\partial D(z_0, \varepsilon)$  in  $D \setminus \{z_0\}$ , then

$$(16.1) \quad \int_C \frac{f(z)}{z - z_0} dz = 2\pi i f(z_0).$$

**Proof.** Since  $z \mapsto \frac{f(z)}{z-z_0}$  is analytic in  $D \setminus \{z_0\}$ , the Cauchy Goursat Theorem implies

$$\begin{aligned} \int_C \frac{f(z)}{z-z_0} dz &= \int_{\partial D(z_0, \varepsilon)} \frac{f(z)}{z-z_0} dz = \int_0^{2\pi} \frac{f(z_0 + \varepsilon e^{i\theta})}{z_0 + \varepsilon e^{i\theta} - z_0} i\varepsilon e^{i\theta} d\theta \\ &= i \int_0^{2\pi} f(z_0 + \varepsilon e^{i\theta}) d\theta \rightarrow i \int_0^{2\pi} f(z_0) d\theta = 2\pi i f(z_0) \text{ as } \varepsilon \downarrow 0. \end{aligned}$$

■

**Example 16.4.** Use complex methods to compute the integral

$$\int_{-\infty}^{\infty} \frac{1}{1+x^2} dx = \pi.$$

This is done by the usual method, namely let  $C_R(\theta) = R e^{i\theta}$  for  $\theta : 0 \rightarrow \pi$ , then

$$\lim_{R \rightarrow \infty} \left| \int_{C_R} \frac{1}{1+z^{2k}} dz \right| \leq \lim_{R \rightarrow \infty} \frac{1}{1-R^{2k}} \pi R = 0$$

and therefore if we let  $\Gamma_R$  be the contour  $[-R, R]$  followed by  $C_R$ , we have

$$\int_{-R}^R \frac{1}{1+x^{2k}} dx = \lim_{R \rightarrow \infty} \int_{[-R, R]} \frac{1}{1+z^{2k}} dz = \lim_{R \rightarrow \infty} \int_{\Gamma_R} \frac{1}{1+z^{2k}} dz.$$

The last integral is independent of  $R > 1$  and can be computed by deforming the contours. For the first case we have

$$\int_{\Gamma_R} \frac{1}{1+z^2} = \int_{\Gamma_R} \frac{1}{(z-i)(z+i)} dz = 2\pi i \frac{1}{i+i} = \pi.$$

## 17. (11/12/2003) LECTURE 17

Gave the second midterm on Monday, 11/10/03.

**Definition 17.1** (Residue). Suppose that  $D$  is a disk centered at  $z_0 \in \mathbb{C}$  and  $f : D \setminus \{z_0\} \rightarrow \mathbb{C}$  is analytic. The **residue of  $f$  at  $z_0$**  is defined by

$$\operatorname{res}_{z_0} f := \frac{1}{2\pi i} \oint_{|z-z_0|=\varepsilon} f(z) dz$$

where  $\varepsilon > 0$  such that the contour  $|z - z_0| = \varepsilon$  is in  $D$ . As usual the contour is given the counter clockwise orientation.

**Lemma 17.2.** Suppose that  $f$  is analytic inside a closed contour  $C$  and only 0 at one point  $z_0$  inside  $C$  and that  $f(z) = \frac{h(z)}{g(z)}$  where  $h$  and  $g$  are analytic functions near  $z_0$  and  $g'(z_0) \neq 0$ , then

$$\operatorname{res}_{z_0} f := \frac{h(z_0)}{g'(z_0)}.$$

**Proof.** Using results that we will prove shortly when considering power series,  $g(z) = (z - z_0)k(z)$  where  $k$  is analytic near  $z_0$  and  $k(z_0) = g'(z_0) \neq 0$ . **Alternatively**, use the fundamental theorem of calculus to write

$$\begin{aligned} g(z) &= g(z) - g(z_0) = \int_0^1 \frac{d}{dt} g(z_0(1-t) + tz) dt \\ &= \int_0^1 (z - z_0) g'(z_0(1-t) + tz) dt \\ &= (z - z_0) k(z) \end{aligned}$$

where  $k(z) := \int_0^1 g'(z_0(1-t) + tz) dt$ . Then  $k(z_0) = g'(z_0)$  and  $k$  is analytic with

$$k'(z) = \int_0^1 g''(z_0(1-t) + tz) t dt$$

as we will show shortly below.

Therefore by the Cauchy integral formula

$$\begin{aligned} \frac{1}{2\pi i} \oint_{|z-z_0|=\varepsilon} f(z) dz &= \frac{1}{2\pi i} \oint_{|z-z_0|=\varepsilon} \frac{h(z)}{g(z)} dz \\ &= \frac{1}{2\pi i} \oint_{|z-z_0|=\varepsilon} \frac{h(z)/k(z)}{(z-z_0)} dz = \frac{h(z_0)}{k(z_0)}. \end{aligned}$$

Since  $g'(z_0) = k(z_0)$ , the result is proved. ■

**Theorem 17.3** (Residue Theorem). Suppose that  $f : D \setminus \{z_1, \dots, z_n\} \rightarrow \mathbb{C}$  is an analytic function and  $C$  is a simple counter clockwise closed contour in  $D$  such that  $C$  “surrounds”  $\{z_1, \dots, z_n\}$ , then

$$\int_C f(z) dz = 2\pi i \sum_{i=1}^n \operatorname{res}_{z_i} f.$$

**Proof.** The proof of this theorem is contained in Figure 4.

■

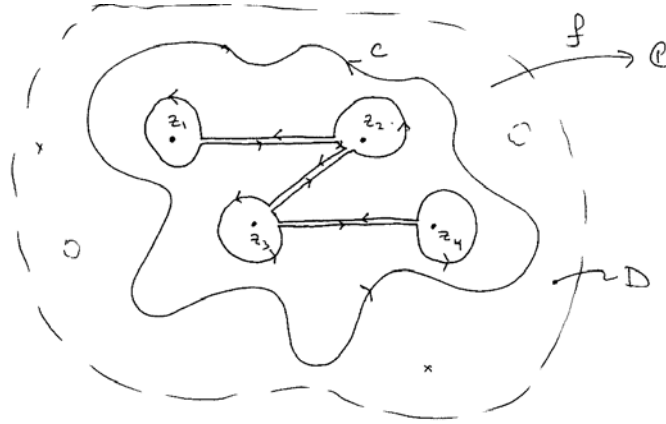

FIGURE 4. Deforming a contour to circles around the singularities of  $f$ . The integration over the parts of the contour indicated by straight lines cancel and so may be ignored.

**Example 17.4.** Use complex methods to compute the integral:

$$\int_{-\infty}^{\infty} \frac{1}{1+x^4} dx = \frac{\pi}{\sqrt{2}}.$$

We will continue the method in Example 16.4 where it was already shown that

$$\begin{aligned} \int_{-\infty}^{\infty} \frac{1}{1+x^4} dx &= \int_{\Gamma_R} \frac{1}{1+z^4} dz \\ &= 2\pi i \sum_{z: z^4+1=0 \text{ with } z \text{ inside } \Gamma_R} \operatorname{res}_z \frac{1}{1+z^4}. \end{aligned}$$

The roots of  $z^4 + 1 = 0$  inside of  $\Gamma_R$  are  $z_0 := e^{i\pi/4} = \frac{1}{\sqrt{2}}(1+i)$  and  $z_1 := e^{i3\pi/4} = \frac{1}{\sqrt{2}}(-1+i)$ , see Figure 5. When  $z$  is a root we have,

$$\operatorname{res}_z \frac{1}{1+z^4} = \frac{1}{4z^3}.$$

Hence

$$\begin{aligned} \int_{-\infty}^{\infty} \frac{1}{1+x^4} dx &= 2\pi i \left[ \frac{1}{4z_0^3} + \frac{1}{4z_1^3} \right] \\ &= \frac{2\pi i}{4} \left\{ e^{-i3\pi/4} + e^{-i\pi/4} \right\} = \frac{\pi i}{2\sqrt{2}} \{-1-i+1-i\} \\ &= \frac{\pi}{\sqrt{2}}. \end{aligned}$$

**Example 17.5.** Compute the integral

$$\int_{-\infty}^{\infty} \frac{e^{i\lambda x}}{1+x^2} dx \text{ for } \lambda \geq 0.$$



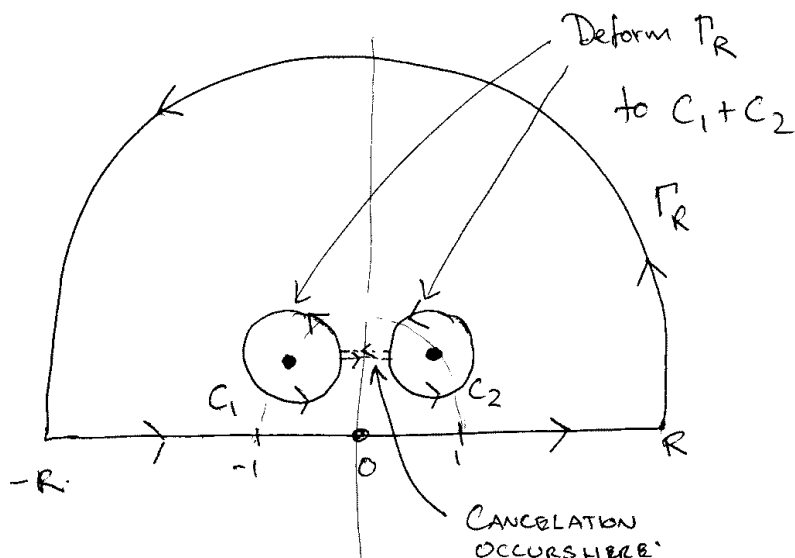

FIGURE 5. Deforming contours to evaluated real integrals.

Close the contour in the upper half plane (note that  $|e^{i\lambda z}| = e^{\operatorname{Re}(i\lambda z)} = e^{-\lambda y} \leq 1$  for  $y \geq 0$ ) doing the usual estimates to show this OK. Hence we have

$$\begin{aligned} \int_{-\infty}^{\infty} \frac{e^{i\lambda x}}{1+x^2} dx &= \int_{\Gamma_R + [-R, R]} \frac{e^{i\lambda z}}{1+z^2} dz = 2\pi i \operatorname{res}_{z=i} \left[ \frac{e^{i\lambda z}}{1+z^2} \right] \\ &= 2\pi i \left[ \frac{e^{i\lambda i}}{2i} \right] = \pi e^{-\lambda}. \end{aligned}$$

Conclude from this that

$$\pi e^{-\lambda} = \int_{-\infty}^{\infty} \frac{e^{i\lambda x}}{1+x^2} dx = \int_{-\infty}^{\infty} \frac{\cos(\lambda x)}{1+x^2} dx + i \int_{-\infty}^{\infty} \frac{\sin(\lambda x)}{1+x^2} dx$$

and hence

$$\begin{aligned} \int_{-\infty}^{\infty} \frac{\cos(\lambda x)}{1+x^2} dx &= \pi e^{-\lambda} \text{ and} \\ \int_{-\infty}^{\infty} \frac{\sin(\lambda x)}{1+x^2} dx &= 0. \end{aligned}$$

## 18. (11/14/2003) LECTURE 18

**Notation 18.1.** We will write  $\Omega \subset_o \mathbb{C}$  if  $\Omega$  is an open subset of  $\mathbb{C}$  and  $f \in H(\Omega)$  if  $f$  is analytic on  $\Omega$ . Also let

$$\begin{aligned} D(z_0, \rho) &= \{z \in \mathbb{C} : |z - z_0| < \rho\} \\ \overline{D(z_0, \rho)} &= \{z \in \mathbb{C} : |z - z_0| \leq \rho\} \text{ and} \\ \partial D(z_0, \rho) &= \{z \in \mathbb{C} : |z - z_0| = \rho\}. \end{aligned}$$

## 18.1. On the proof of the Cauchy Goursat Theorem.

**Theorem 18.2** (Differentiating under the integral sign). *Suppose that  $f(t, z)$  is a continuous function in  $(t, z)$  for  $a \leq t \leq b$  and  $z$  near  $z_0 \in \mathbb{F}$  where  $\mathbb{F} = \mathbb{R}$  or  $\mathbb{C}$ . Further assume that  $\frac{\partial f(t, z)}{\partial z}$  exists and is continuous in  $(t, z)$  with  $z$  near  $z_0$ , then*

$$\frac{d}{dz} \int_a^b f(t, z) dt = \int_a^b \frac{\partial f(t, z)}{\partial z} dt.$$

Moreover the function  $z \rightarrow \int_a^b \frac{\partial f(t, z)}{\partial z} dt$  is continuous in  $z$  near  $z_0$ .

**Proof.** (Sketch Briefly!) Let

$$F(z) := \int_a^b f(t, z) dt,$$

then

(18.1)

$$\frac{F(z+h) - F(z)}{h} - \int_a^b \frac{\partial f(t, z)}{\partial z} dt = \int_a^b \left[ \frac{f(t, z+h) - f(t, z)}{h} - \frac{\partial f(t, z)}{\partial z} \right] dt$$

and

$$\frac{f(t, z+h) - f(t, z)}{h} = \frac{1}{h} \int_0^1 \frac{d}{ds} f(t, z+sh) ds = \int_0^1 \frac{\partial f}{\partial z}(t, z+sh) ds.$$

Therefore,

$$\begin{aligned} \left| \frac{f(t, z+h) - f(t, z)}{h} - \frac{\partial f(t, z)}{\partial z} \right| &= \left| \int_0^1 \left[ \frac{\partial f}{\partial z}(t, z+sh) - \frac{\partial f(t, z)}{\partial z} \right] ds \right| \\ &\leq \int_0^1 \left| \frac{\partial f}{\partial z}(t, z+sh) - \frac{\partial f(t, z)}{\partial z} \right| ds \\ &\leq \max_{s \in [0,1]} \left| \frac{\partial f}{\partial z}(t, z+sh) - \frac{\partial f(t, z)}{\partial z} \right| \end{aligned}$$

and the latter term goes to 0 uniformly in  $t$  as  $h \rightarrow 0$  by uniform continuity of  $\frac{\partial f}{\partial z}(t, z)$ . Therefore we can let  $h \rightarrow 0$  in Eq. (18.1) to find

$$\int_a^b \left[ \frac{f(t, z+h) - f(t, z)}{h} - \frac{\partial f(t, z)}{\partial z} \right] dt \rightarrow 0 \text{ as } h \rightarrow 0$$

and hence

$$\lim_{h \rightarrow 0} \frac{F(z+h) - F(z)}{h} = \int_a^b \frac{\partial f(t, z)}{\partial z} dt.$$

The continuity in  $z$  is proved similarly,

$$\left| \int_a^b \frac{\partial f(t, z+h)}{\partial z} dt - \int_a^b \frac{\partial f(t, z)}{\partial z} dt \right| \leq \int_a^b \left| \frac{\partial f(t, z+h)}{\partial z} - \frac{\partial f(t, z)}{\partial z} \right| dt \rightarrow 0 \text{ as } h \rightarrow 0$$

by the same uniform continuity arguments used above. ■

**Notation 18.3.** Given  $D \subset_o \mathbb{C}$  and a  $C^2$  map  $\sigma : [a, b] \times [0, 1] \rightarrow D$ , let  $\sigma_s := \sigma(\cdot, s) \in C^1([a, b] \rightarrow D)$ . In this way, the map  $\sigma$  may be viewed as a map

$$s \in [0, 1] \rightarrow \sigma_s := \sigma(\cdot, s) \in C^2([a, b] \rightarrow D),$$

i.e.  $s \rightarrow \sigma_s$  is a path of contours in  $D$ .

**Definition 18.4.** Given a region  $D$  and  $\alpha, \beta \in C^2([a, b] \rightarrow D)$ , we will write  $\alpha \simeq \beta$  in  $D$  provided there exists a  $C^2$  - map  $\sigma : [a, b] \times [0, 1] \rightarrow D$  such that  $\sigma_0 = \alpha$ ,  $\sigma_1 = \beta$ , and  $\sigma$  satisfies either of the following two conditions:

- (1)  $\frac{d}{ds}\sigma(a, s) = \frac{d}{ds}\sigma(b, s) = 0$  for all  $s \in [0, 1]$ , i.e. the end points of the paths  $\sigma_s$  for  $s \in [0, 1]$  are fixed.
- (2)  $\sigma(a, s) = \sigma(b, s)$  for all  $s \in [0, 1]$ , i.e.  $\sigma_s$  is a loop in  $D$  for all  $s \in [0, 1]$ .

See Figure 6.

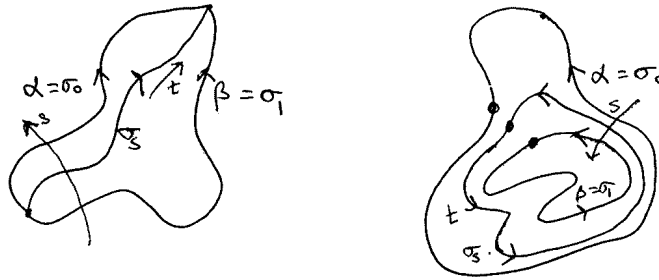

FIGURE 6. Smooth homotopy of open paths and loops.

**Proposition 18.5** (Baby Cauchy – Goursat Theorem). *Let  $D$  be a region and  $\alpha, \beta \in C^2([a, b], D)$  be two contours such that  $\alpha \simeq \beta$  in  $D$ . Then*

$$\int_{\alpha} f(z)dz = \int_{\beta} f(z)dz \text{ for all } f \in H(D) \cap C^1(D).$$

**Proof.** Let  $\sigma : [a, b] \times [0, 1] \rightarrow D$  be as in Definition 18.4, then it suffices to show the function

$$F(s) := \int_{\sigma_s} f(z)dz$$

is constant for  $s \in [0, 1]$ . For this we compute:

$$\begin{aligned} F'(s) &= \frac{d}{ds} \int_a^b f(\sigma(t, s))\dot{\sigma}(t, s)dt = \int_a^b \frac{d}{ds} [f(\sigma(t, s))\dot{\sigma}(t, s)] dt \\ &= \int_a^b \{f'(\sigma(t, s))\sigma'(t, s)\dot{\sigma}(t, s) + f(\sigma(t, s))\dot{\sigma}'(t, s)\} dt \\ &= \int_a^b \frac{d}{dt} [f(\sigma(t, s))\sigma'(t, s)] dt \\ &= [f(\sigma(t, s))\sigma'(t, s)] \Big|_{t=a}^{t=b} = 0 \end{aligned}$$

where the last equality is a consequence of either of the two endpoint assumptions of Definition 18.4. ■

Recall the Cauchy integral formula states,

$$(18.2) \quad f(z) = \frac{1}{2\pi i} \int_C \frac{f(w)}{w-z} dw$$

where  $C$  is simple closed contour in  $\Omega$  traversed in the counter clockwise direction,  $z$  is inside  $C$  and  $f \in H(\Omega)$ . Using the results in Proposition 18.5 we can rigorously prove Eq. (18.2) for  $f \in H(D) \cap C^1(D)$  and for those contours  $C$  which are  $C^2$  – homotopic to  $\partial D(z, \delta)$  for some  $\delta > 0$ . Using Theorem 18.2, we may differentiate Eq. (18.2) with respect to  $z$  repeatedly to learn the following theorem.

**Theorem 18.6.** *Suppose  $f \in H(\Omega) \cap C^1(\Omega)$ ,<sup>1</sup> then  $f^{(n)}$  exists and  $f^{(n)} \in H(\Omega)$  for all  $n \in \mathbb{N}$ . Moreover if  $D$  is a disk such that  $\bar{D} \subset \Omega$ , then*

$$(18.3) \quad f^{(n)}(z) = \frac{n!}{2\pi i} \oint_{\partial D} \frac{f(w)}{(w-z)^{n+1}} dw \text{ for all } z \in D.$$

**Corollary 18.7** (Cauchy Estimates). *Suppose that  $f \in H(\Omega)$  where  $\Omega \subset_o \mathbb{C}$  and suppose that  $\overline{D(z_0, \rho)} \subset \Omega$ , then*

$$(18.4) \quad \left| f^{(n)}(z_0) \right| \leq \frac{n!}{\rho^n} M_\rho$$

where

$$M_\rho := \sup_{|w-z_0|=\rho} |f(w)|$$

**Proof.** From Eq. (18.3) evaluated at  $z = z_0$  with  $C = \partial D(z_0, \rho)$ , we have

$$\left| f^{(n)}(z_0) \right| = \left| \frac{n!}{2\pi i} \oint_C \frac{f(w)}{(w-z_0)^{n+1}} dw \right| \leq \frac{n!}{2\pi} \frac{M_\rho}{\rho^{n+1}} 2\pi\rho.$$

■

---

<sup>1</sup>As we will see later in Theorem 19.5, the assumption that  $f$  is  $C^1$  in this condition is redundant. Complex differentiability of  $f$  at all points  $z \in \Omega$  already implies that  $f$  is  $C^\infty(\Omega, \mathbb{C})$ !!

19. (11/17/2003) LECTURE 19

**Theorem 19.1** (Morera's Theorem). *Suppose that  $\Omega \subset_o \mathbb{C}$  and  $f \in C(\Omega)$  is a complex function such that*

$$(19.1) \quad \int_{\partial T} f(z)dz = 0 \text{ for all solid triangles } T \subset \Omega,$$

then  $f \in H(\Omega)$  and  $f^{(n)}$  exists for all  $n$ , so  $f^{(n)} \in H(\Omega)$  for all  $n \in \mathbb{N} \cup \{0\}$ .

**Proof.** Let  $D = D(z_0, \rho)$  be a disk such that  $\bar{D} \subset \Omega$  and for  $z \in D$  let

$$F(z) = \int_{[z_0, z]} f(\xi)d\xi$$

where  $[z_0, z]$  is by definition the contour,  $\sigma(t) = (1-t)z_0 + tz$  for  $0 \leq t \leq 1$ , see Figure 7. For  $z \in D$  and  $h$  small so that  $z+h \in D$  we have, using Eq. (19.1),

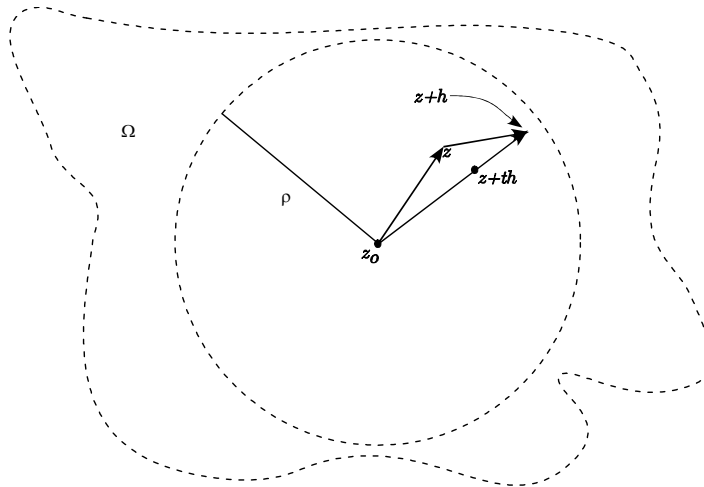

FIGURE 7. Constructing a locally defined anti-derivative fo  $f$  to show that  $f$  is analytic.

$$F(z+h) - F(z) = \int_{[z, z+h]} f(w)dw = \int_0^1 f(z+th)hdt = h \int_0^1 f(z+th)dt$$

wherein we have parametrized  $[z, z+h]$  as  $w = z+th$ . From this equation and the continuity of  $f$ ,

$$\frac{F(z+h) - F(z)}{h} = \int_0^1 f(z+th)dt \rightarrow f(z) \text{ as } h \rightarrow 0.$$

Hence  $F' = f$  so that  $F \in H(D) \cap C^1(D)$ . Theorem 18.6 now implies that  $F^{(n)}$  exists for all  $n$  and hence  $f^{(n)} = F^{(n+1)} \in H(D)$  exists for all  $n$ . Since  $D$  was an arbitrary disk contained in  $\Omega$  and the condition for being in  $H(\Omega)$  is local we conclude that  $f \in H(\Omega)$  and  $f^{(n)} \in H(\Omega)$  for all  $n$ . ■

19.1. The material in this section was not covered in class.

**Theorem 19.2** (A variant of Morera's Theorem). *(This may be skipped.)* Suppose that  $f$  is a continuous function on a domain  $D$  such that  $\int_{\alpha} f(z) dz$  only depends on the end points of  $\alpha$ , for example if  $D$  is simply connected and  $f$  is analytic on  $D$ . Then  $f$  has an anti-derivative,  $F$ . Namely, fix a  $z_0 \in D$  and let  $C_z$  denote a contour in  $D$  such that  $C_z(0) = z_0$  and  $C_z(1) = z$ , then we may define

$$F(z) := \int_{C_z} f(w) dw.$$

**Proof.** Let  $[z, z+h]$  denote the contour  $C(t) := z+th$  for  $t: 0 \rightarrow 1$ . Then

$$\begin{aligned} F(z+h) - F(z) &= \int_{C_{z+h}} f(w) dw - \int_{C_z} f(w) dw \\ &= \int_{C_{z+h} - C_z} f(w) dw = \int_{[z, z+h]} f(w) dw \end{aligned}$$

wherein the last equality we have used the fact that  $C_{z+h} - C_z$  and  $[z, z+h]$  are contours with the same endpoints. Using this formula

$$\begin{aligned} \frac{F(z+h) - F(z)}{h} &= \frac{1}{h} \int_0^1 f(z+th) h dt \\ &= \int_0^1 f(z+th) dt \rightarrow f(z) \text{ as } h \rightarrow 0. \end{aligned}$$

■

The next theorem is the deepest theorem of this section.

**Theorem 19.3** (Converse of Morera's Theorem). Let  $\Omega \subset \mathbb{C}$  and  $f: \Omega \rightarrow \mathbb{C}$  is a function which is complex differentiable at each point  $z \in \Omega$ . Then  $\oint_{\partial T} f(z) dz = 0$  for all solid triangles  $T \subset \Omega$ .

**Proof.** Write  $T = S_1 \cup S_2 \cup S_3 \cup S_4$  as in Figure 8 below.

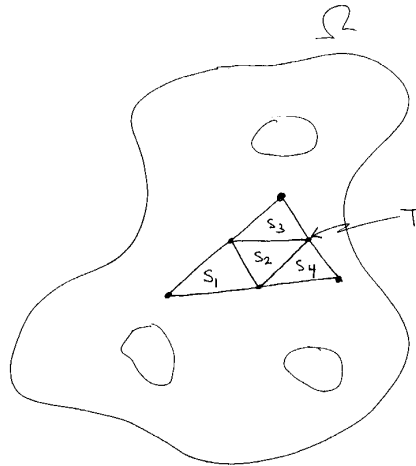

FIGURE 8. Splitting  $T$  into four similar triangles of equal size.

Let  $T_1 \in \{S_1, S_2, S_3, S_4\}$  such that  $|\int_{\partial T} f(z)dz| = \max\{|\int_{\partial S_i} f(z)dz| : i = 1, 2, 3, 4\}$ , then

$$|\int_{\partial T} f(z)dz| = |\sum_{i=1}^4 \int_{\partial S_i} f(z)dz| \leq \sum_{i=1}^4 |\int_{\partial S_i} f(z)dz| \leq 4|\int_{\partial T_1} f(z)dz|.$$

Repeating the above argument with  $T$  replaced by  $T_1$  again and again, we find by induction there are triangles  $\{T_i\}_{i=1}^\infty$  such that

- (1)  $T \supseteq T_1 \supseteq T_2 \supseteq T_3 \supseteq \dots$
- (2)  $\ell(\partial T_n) = 2^{-n}\ell(\partial T)$  where  $\ell(\partial T)$  denotes the length of the boundary of  $T$ ,
- (3)  $\text{diam}(T_n) = 2^{-n} \text{diam}(T)$  and

$$(19.2) \quad |\int_{\partial T} f(z)dz| \leq 4^n |\int_{\partial T_n} f(z)dz|.$$

By finite intersection property of compact sets there exists  $z_0 \in \bigcap_{n=1}^\infty T_n$ . Because

$$f(z) = f(z_0) + f'(z_0)(z - z_0) + o(z - z_0)$$

we find

$$\begin{aligned} \left| 4^n \int_{\partial T_n} f(z)dz \right| &= 4^n \left| \int_{\partial T_n} f(z_0)dz + \int_{\partial T_n} f'(z_0)(z - z_0)dz + \int_{\partial T_n} o(z - z_0)dz \right| \\ &= 4^n \left| \int_{\partial T_n} o(z - z_0)dz \right| \leq C\epsilon_n 4^n \int_{\partial T_n} |z - z_0| d|z| \end{aligned}$$

where  $\epsilon_n \rightarrow 0$  as  $n \rightarrow \infty$ . Since

$$\begin{aligned} \int_{\partial T_n} |z - z_0| d|z| &\leq \text{diam}(T_n)\ell(\partial T_n) = 2^{-n}\text{diam}(T)2^{-n}\ell(\partial T) \\ &= 4^{-n}\text{diam}(T)\ell(\partial T) \end{aligned}$$

we see

$$4^n \left| \int_{\partial T_n} f(z)dz \right| \leq C\epsilon_n 4^n 4^{-n}\text{diam}(T)\ell(\partial T) = C\epsilon_n \rightarrow 0 \text{ as } n \rightarrow \infty.$$

Hence by Eq. (19.2),  $\int_{\partial T} f(z)dz = 0$ . ■

The method of the proof above also gives the following corollary.

**Corollary 19.4.** *Suppose that  $\Omega \subset_o \mathbb{C}$  is convex open set. Then for every  $f \in H(\Omega)$  there exists  $F \in H(\Omega)$  such that  $F' = f$ . In fact fixing a point  $z_0 \in \Omega$ , we may define  $F$  by*

$$F(z) = \int_{[z_0, z]} f(\xi)d\xi \text{ for all } z \in \Omega.$$

By combining Theorem 19.1 and Theorem 19.3 we arrive at the important result.

**Theorem 19.5.** *Suppose that  $f \in H(\Omega)$ , then  $f' \in H(\Omega)$  and hence by induction,  $f^{(n)}$  exists and  $f^{(n)} \in H(\Omega)$  for all  $n \in \mathbb{N} \cup \{0\}$ .*

**Exercise 19.6.** Let  $\Omega \subset_o \mathbb{C}$  and  $\{f_n\} \subset H(\Omega)$  be a sequence of functions such that  $f(z) = \lim_{n \rightarrow \infty} f_n(z)$  exists for all  $z \in \Omega$  and the convergence is uniform on compact subsets of  $\Omega$ . Show  $f \in H(\Omega)$  and  $f'(z) = \lim_{n \rightarrow \infty} f'_n(z)$ .

**Hint:** Use Morera's theorem to show  $f \in H(\Omega)$  and then use Eq. (26.3) with  $n = 1$  to prove  $f'(z) = \lim_{n \rightarrow \infty} f'_n(z)$ .

**19.2. More Applications of the Cauchy Goursat and the Cauchy Integral Formula.** The next two results were covered in class.

**Corollary 19.7** (Liouville's Theorem). *If  $f \in H(\mathbb{C})$  and  $f$  is bounded then  $f$  is constant.*

**Proof.** This follows from Eq. (18.4) with  $n = 1$  and the letting  $n \rightarrow \infty$  to find  $f'(z_0) = 0$  for all  $z_0 \in \mathbb{C}$ . ■

**Corollary 19.8** (Fundamental theorem of algebra). *Every polynomial  $p(z)$  of degree larger than 0 has a root in  $\mathbb{C}$ .*

**Proof.** Suppose that  $p(z)$  is polynomial with no roots in  $z$ . Then  $f(z) = 1/p(z)$  is a bounded holomorphic function and hence constant. This shows that  $p(z)$  is a constant, i.e.  $p$  has degree zero. ■

19.2.1. *The remainder of this subsection was not done in class.*

**Corollary 19.9** (Mean value property). *Let  $\Omega \subset_o \mathbb{C}$  and  $f \in H(\Omega)$ , then  $f$  satisfies the mean value property*

$$(19.3) \quad f(z_0) = \frac{1}{2\pi} \int_0^{2\pi} f(z_0 + \rho e^{i\theta}) d\theta$$

which holds for all  $z_0$  and  $\rho \geq 0$  such that  $\overline{D(z_0, \rho)} \subset \Omega$ .

**Proof.** By Cauchy's integral formula and parametrizing  $\partial D(z_0, \rho)$  as  $z = z_0 + \rho e^{i\theta}$ , we learn

$$\begin{aligned} f(z_0) &= \frac{1}{2\pi i} \int_{\partial D(z_0, \rho)} \frac{f(z)}{z - z_0} dz = \frac{1}{2\pi i} \int_0^{2\pi} \frac{f(z_0 + \rho e^{i\theta})}{\rho e^{i\theta}} i \rho e^{i\theta} d\theta \\ &= \frac{1}{2\pi} \int_0^{2\pi} f(z_0 + \rho e^{i\theta}) d\theta. \end{aligned}$$

■

**Proposition 19.10.** *Suppose that  $\Omega$  is a connected open subset of  $\mathbb{C}$ . If  $f \in H(\Omega)$  is a function such that  $|f|$  has a local maximum at  $z_0 \in \Omega$ , then  $f$  is constant.*

**Proof.** Let  $\rho > 0$  such that  $\bar{D} = \overline{D(z_0, \rho)} \subset \Omega$  and  $|f(z)| \leq |f(z_0)| =: M$  for  $z \in \bar{D}$ . By replacing  $f$  by  $e^{i\theta} f$  with an appropriate  $\theta \in \mathbb{R}$  we may assume  $M = f(z_0)$ . Letting  $u(z) = \operatorname{Re} f(z)$  and  $v(z) = \operatorname{Im} f(z)$ , we learn from Eq. (19.3) that

$$\begin{aligned} M &= f(z_0) = \operatorname{Re} f(z_0) = \frac{1}{2\pi} \int_0^{2\pi} u(z_0 + \rho e^{i\theta}) d\theta \\ &\leq \frac{1}{2\pi} \int_0^{2\pi} \min(u(z_0 + \rho e^{i\theta}), 0) d\theta \leq M \end{aligned}$$



since  $|u(z_0 + \rho e^{i\theta})| \leq |f(z_0 + \rho e^{i\theta})| \leq M$  for all  $\theta$ . From the previous equation it follows that

$$0 = \int_0^{2\pi} \{M - \min(u(z_0 + \rho e^{i\theta}), 0)\} d\theta$$

which in turn implies that  $M = \min(u(z_0 + \rho e^{i\theta}), 0)$ , since  $\theta \rightarrow M - \min(u(z_0 + \rho e^{i\theta}), 0)$  is positive and continuous. So we have proved  $M = u(z_0 + \rho e^{i\theta})$  for all  $\theta$ . Since

$$M^2 \geq |f(z_0 + \rho e^{i\theta})|^2 = u^2(z_0 + \rho e^{i\theta}) + v^2(z_0 + \rho e^{i\theta}) = M^2 + v^2(z_0 + \rho e^{i\theta}),$$

we find  $v(z_0 + \rho e^{i\theta}) = 0$  for all  $\theta$ . Thus we have shown  $f(z_0 + \rho e^{i\theta}) = M$  for all  $\theta$  and hence by Corollary 27.8,  $f(z) = M$  for all  $z \in \Omega$ . ■

The following lemma makes the same conclusion as Proposition 19.10 using the Cauchy Riemann equations. This Lemma may be skipped.

**Lemma 19.11.** *Suppose that  $f \in H(D)$  where  $D = D(z_0, \rho)$  for some  $\rho > 0$ . If  $|f(z)| = k$  is constant on  $D$  then  $f$  is constant on  $D$ .*

**Proof.** If  $k = 0$  we are done, so assume that  $k > 0$ . By assumption

$$\begin{aligned} 0 &= \partial k^2 = \partial |f|^2 = \partial(\bar{f}f) = \partial\bar{f} \cdot f + \bar{f}\partial f \\ &= \bar{f}\partial f = \bar{f}f' \end{aligned}$$

wherein we have used

$$\partial\bar{f} = \frac{1}{2}(\partial_x - i\partial_y)\bar{f} = \frac{1}{2}\overline{(\partial_x + i\partial_y)f(z)} = \overline{\partial f} = 0$$

by the Cauchy Riemann equations. Hence  $f' = 0$  and  $f$  is constant. ■

**Corollary 19.12** (Maximum modulus principle). *Let  $\Omega$  be a bounded region and  $f \in C(\bar{\Omega}) \cap H(\Omega)$ . Then for all  $z \in \Omega$ ,  $|f(z)| \leq \sup_{z \in \partial\Omega} |f(z)|$ . Furthermore if there exists  $z_0 \in \Omega$  such that  $|f(z_0)| = \sup_{z \in \partial\Omega} |f(z)|$  then  $f$  is constant.*

**Proof.** If there exists  $z_0 \in \Omega$  such that  $|f(z_0)| = \max_{z \in \partial\Omega} |f(z)|$ , then Proposition 19.10 implies that  $f$  is constant and hence  $|f(z_0)| = \sup_{z \in \partial\Omega} |f(z)|$ . If no such  $z_0$  exists then  $|f(z)| \leq \sup_{z \in \partial\Omega} |f(z)|$  for all  $z \in \bar{\Omega}$ . ■

### 19.3. Series.

**Definition 19.13.** Given a sequence  $\{z_n\}_{n=0}^\infty$ , we say the sum,  $\sum_{n=0}^\infty z_n =: S$  exists or  $\sum_{n=0}^\infty z_n$  is convergent if the sequence

$$S_N := \sum_{n=0}^N z_n \rightarrow S \text{ as } N \rightarrow \infty.$$

We say that  $\sum_{n=0}^\infty z_n$  is absolutely convergent if  $\sum_{n=0}^\infty |z_n| < \infty$ .

*Remark 19.14.* Since  $\lim_{N \rightarrow \infty} S_N = S$  iff  $\lim_{N \rightarrow \infty} \operatorname{Re} S_N = \operatorname{Re} S$  and  $\lim_{N \rightarrow \infty} \operatorname{Im} S_N = \operatorname{Im} S$ , it follows that  $\sum_{n=0}^\infty z_n$  exists iff  $\sum_{n=0}^\infty \operatorname{Re} z_n$  and  $\sum_{n=0}^\infty \operatorname{Im} z_n$  exists. In this case

$$\sum_{n=0}^\infty z_n = \sum_{n=0}^\infty \operatorname{Re} z_n + i \sum_{n=0}^\infty \operatorname{Im} z_n.$$

**Proposition 19.15** (Completeness of  $\mathbb{C}$ ). *If  $\sum_{n=0}^{\infty} |z_n| < \infty$  then  $\sum_{n=0}^{\infty} z_n$  exists and*

$$(19.4) \quad \left| \sum_{n=0}^{\infty} z_n \right| \leq \sum_{n=0}^{\infty} |z_n|.$$

**Proof.** (Skip the proof and just take this as a basic fact.) Because of Remark 19.14 and the estimates,

$$\sum_{n=0}^{\infty} |\operatorname{Re} z_n| \leq \sum_{n=0}^{\infty} |z_n| < \infty \quad \text{and} \quad \sum_{n=0}^{\infty} |\operatorname{Im} z_n| \leq \sum_{n=0}^{\infty} |z_n| < \infty$$

it suffices to consider the real case. Now for  $M > N$  we have

$$\begin{aligned} |S_N - S_M| &= \left| \sum_{n=M+1}^N z_n \right| \leq \sum_{n=M+1}^N |z_n| \leq \sum_{n=M+1}^{\infty} |z_n| \\ &= \sum_{n=0}^{\infty} |z_n| - \sum_{n=0}^M |z_n| \rightarrow 0 \quad \text{as } M, N \rightarrow \infty. \end{aligned}$$

Therefore by the basic “completeness” of the real numbers,  $\lim_{N \rightarrow \infty} S_N$  exists. For the estimate in Eq. (19.4), we have

$$\left| \sum_{n=0}^{\infty} z_n \right| = \lim_{N \rightarrow \infty} \left| \sum_{n=0}^N z_n \right| \leq \lim_{N \rightarrow \infty} \sum_{n=0}^N |z_n| = \sum_{n=0}^{\infty} |z_n|.$$

■

**Example 19.16.** Let  $z \in \mathbb{C}$  and let us consider the geometric series  $\sum_{n=0}^{\infty} z^n$ . In this case we may find the partial sums,  $S_N := \sum_{n=0}^N z^n$  explicitly since

$$S_N - zS_N = 1 - z^{N+1}.$$

Solving this equation for  $S_N$  then implies

$$S_N = \begin{cases} \frac{1-z^{N+1}}{1-z} & \text{if } z \neq 1 \\ N+1 & \text{if } z = 1. \end{cases}$$

From this expression we see that  $\sum_{n=0}^{\infty} z^n$  exists iff  $|z| < 1$  and in which case

$$\sum_{n=0}^{\infty} z^n = \frac{1}{1-z}.$$

Let us note that

$$\begin{aligned} R_N(z) &= \frac{1}{1-z} - \sum_{n=0}^N z^n = \frac{1}{1-z} - \frac{1-z^{N+1}}{1-z} \\ &= \frac{z^{N+1}}{1-z} \end{aligned}$$

so that

$$(19.5) \quad \frac{1}{1-z} = \sum_{n=0}^N z^n + R_N(z)$$

and

$$|R_N(z)| = \frac{|z|^{N+1}}{|1-z|} \leq \frac{|z|^{N+1}}{1-|z|} \text{ for } |z| < 1.$$

*Remark 19.17.* More generally the same argument shows

$$(19.6) \quad \sum_{k=n}^m z^k = \frac{z^{m+1} - z^n}{z-1} \text{ if } z \neq 1.$$

**Example 19.18.** Also showed

$$\frac{1}{1+z^2} = \sum_{n=0}^{\infty} (-1)^n z^{2n} \text{ for } |z| < 1$$

and explained why the series only converges for  $|z| < 1$  by looking at the location of the poles of the function  $f(z) = \frac{1}{1+z^2}$ .

## 20. (11/19/2003) LECTURE 20

**Theorem 20.1** (Differentiating and integrating a sum of analytic functions). *Suppose that  $f_n : \Omega \rightarrow \mathbb{C}$  is a sequence of analytic functions such that*

$$|f_n(z)| \leq M_n \text{ for all } n \in \mathbb{N} \text{ and } z \in \mathbb{C}$$

where  $\sum_{n=1}^{\infty} M_n < \infty$ . Then

(1) *If  $C$  is any contour in  $\Omega$ , we have*

$$\int_C F(z) dz = \sum_{n=1}^{\infty} \int_C f_n(z) dz.$$

(2) *The function  $F(z) := \sum_{n=1}^{\infty} f_n(z)$  is an analytic.*

(3)  *$F'(z) = \sum_{n=1}^{\infty} f'_n(z)$  and in fact*

$$(20.1) \quad F^{(k)}(z) = \sum_{n=1}^{\infty} f_n^{(k)}(z) \text{ for all } k \in \mathbb{N}_0 \text{ and } z \in \Omega.$$

*Part of the assertion here is that all sums appearing are absolutely convergent.*

**Proof.** Later. ■

*Remark 20.2* (Theorem 20.1 does not hold for real variable functions). It should be noted that Eq. (20.1) is not correct when  $z$  is replaced by a real variable. For example, the series

$$(20.2) \quad F(x) := \sum_{n=1}^{\infty} \frac{\sin nx}{n^2}$$

is perfectly convergent for all  $x \in \mathbb{R}$ , however if we differentiate it once or twice we get

$$\sum_{n=1}^{\infty} \frac{\cos nx}{n} \text{ and } -\sum_{n=1}^{\infty} \sin nx$$

which are no longer convergent. To understand a little better what is going on, notice that the series

$$\sum_{n=1}^{\infty} \frac{\sin nz}{n^2} = \sum_{n=1}^{\infty} \frac{e^{inx} e^{-ny} + e^{inx} e^{ny}}{2in^2}$$

is not convergent if  $z = x + iy$  with  $y \neq 0$ . This is simply because,

$$\lim_{n \rightarrow \infty} \left| \frac{e^{inx} e^{-ny} + e^{inx} e^{ny}}{2in^2} \right| = \infty \text{ in this case.}$$

**Example 20.3.** Differentiating the formula,

$$\frac{1}{1-z} = \sum_{n=0}^{\infty} z^n \text{ for } |z| < 1$$

gives

$$\frac{1}{(1-z)^2} = \sum_{n=0}^{\infty} n z^{n-1}$$

and differentiating again gives

$$\frac{2!}{(1-z)^3} = \sum_{n=0}^{\infty} n(n-1) z^{n-2}$$

and repeating to get

$$\frac{m!}{(1-z)^{m+1}} = \sum_{n=0}^{\infty} [n(n-1)\cdots(n-m+1)] z^{n-m}.$$

**Example 20.4.** Integrating the formula

$$-\frac{d}{dz} \text{Log}(1-z) = \frac{1}{1-z} = \sum_{n=0}^{\infty} z^n$$

implies

$$\begin{aligned} -\text{Log}(1-z) &= \int_0^z -\frac{d}{dw} \text{Log}(1-w) dw = \int_0^z \sum_{n=0}^{\infty} w^n dw \\ &= \sum_{n=0}^{\infty} (-1)^n \int_0^z w^n dw \\ &= \sum_{n=0}^{\infty} \frac{1}{n+1} z^{n+1} \text{ if } |z| < 1. \end{aligned}$$

which implies

$$\text{Log}(1-z) = -\sum_{n=0}^{\infty} \frac{1}{n+1} z^{n+1} \text{ if } |z| < 1.$$

**Theorem 20.5** (Taylor's Theorem). *Let  $\Omega \subset_o \mathbb{C}$  be an open set,  $f \in H(\Omega)$  and  $D = D(z_0, \rho)$  is a disk such that  $\bar{D} \subset \Omega$  then*

$$(20.3) \quad f(z) = \sum_{n=0}^{\infty} a_n (z - z_0)^n \text{ for all } z \in D.$$

where

$$(20.4) \quad a_n = \frac{f^{(n)}(z_0)}{n!} = \frac{1}{2\pi i} \oint_{\partial D} \frac{f(w)}{(w - z_0)^{n+1}} dw.$$

**Proof.** Let  $g(z) := f(z_0 + z)$  and  $r < \rho$  and  $|z| < r$ , then for  $|w| = r$ ,

$$\frac{1}{w - z} = \frac{1}{w} \frac{1}{1 - z/w} = \frac{1}{w} \sum_{n=0}^{\infty} \left(\frac{z}{w}\right)^n.$$

Applying Theorem 20.1 with  $f_n(w) = g(w) \frac{1}{w} \left(\frac{z}{w}\right)^n$  and  $M_n = \max_D |f| \frac{1}{r} \left(\frac{\rho}{r}\right)^n$  we find using the Cauchy integral formula that

$$\begin{aligned} f(z_0 + z) = g(z) &= \frac{1}{2\pi i} \oint_{|w|=r} \frac{g(w)}{(w - z)} dw = \frac{1}{2\pi i} \oint_{|w|=r} \sum_{n=0}^{\infty} g(w) \frac{1}{w} \left(\frac{z}{w}\right)^n dw \\ (20.5) \quad &= \sum_{n=0}^{\infty} \left[ \frac{1}{2\pi i} \oint_{|w|=r} \frac{g(w)}{w^{n+1}} dw \right] z^n = \sum_{n=0}^{\infty} a_n z^n \end{aligned}$$

where

$$\begin{aligned} a_n &= \frac{1}{2\pi i} \oint_{|w|=r} \frac{g(w)}{w^{n+1}} dw = \frac{g^{(n)}(0)}{n!} = \frac{f^{(n)}(z_0)}{n!} \\ &= \frac{1}{2\pi i} \oint_{|w-z_0|=r} \frac{f(w)}{(w - z_0)^{n+1}} dw. \end{aligned}$$

Replacing  $z$  by  $z - z_0$  in Eq. (20.5) completes the proof of Eq. (20.3). ■

**Example 20.6.** (1) Suppose  $f(z) = \frac{1}{1-z}$ , then  $f^{(n)}(z) = \frac{n!}{(1-z)^{n+1}}$  and hence  $f^{(n)}(0) = n!$  and we find again that

$$\frac{1}{1-z} = \sum_{n=0}^{\infty} \frac{n!}{n!} z^n = \sum_{n=0}^{\infty} z^n.$$

(2) Suppose we wish to find the power series expansion of  $f(z) = \frac{1}{1-z}$  centered at 3 which will necessarily converge if  $|z-3| < 2$ . To do this write  $z = 3+h$  so that

$$\begin{aligned} f(z) &= \frac{1}{1-(3+h)} = \frac{1}{-2-h} = -\frac{1}{2} \frac{1}{1+h/2} = -\frac{1}{2} \sum_{n=0}^{\infty} \left(-\frac{h}{2}\right)^n \\ &= \sum_{n=0}^{\infty} \left(\frac{-1}{2}\right)^{n+1} (z-3)^n. \end{aligned}$$

**Moral:** try to avoid computing derivatives whenever possible.

(3) Since  $\frac{d^n}{dz^n} e^z = e^z$  for all  $n$ ,

$$e^z = \sum_{n=0}^{\infty} \frac{1}{n!} z^n$$

which is convergent for all  $z \in \mathbb{C}$  since  $e^z$  is entire.

(4) By substituting  $-z$  for  $z$ ,

$$e^{-z} = \sum_{n=0}^{\infty} \frac{(-1)^n}{n!} z^n.$$

and  $z^3$  for  $z$  we find

$$e^{z^3} = \sum_{n=0}^{\infty} \frac{1}{n!} z^{3n}$$

(5) Since

$$e^{z_0+h} = e^{z_0} e^h = \sum_{n=0}^{\infty} e^{z_0} \frac{h^n}{n!}$$

we have writing  $z = z_0 + h$ , that

$$e^z = \sum_{n=0}^{\infty} e^{z_0} \frac{(z-z_0)^n}{n!}.$$

(6) Similarly,

$$\begin{aligned} e^{iz} &= \sum_{n=0}^{\infty} \frac{(iz)^n}{n!} = \sum_{n=0}^{\infty} \frac{(i)^n}{n!} z^n = \sum_{n=0}^{\infty} \frac{(i)^{2n}}{(2n)!} z^{2n} + \sum_{n=0}^{\infty} \frac{(i)^{2n+1}}{(2n+1)!} z^{2n+1} \\ &= \sum_{n=0}^{\infty} \frac{(-1)^n}{(2n)!} z^{2n} + i \sum_{n=0}^{\infty} \frac{(-1)^n}{(2n+1)!} z^{2n+1}. \end{aligned}$$

From this we deduce that

$$\sin z = \frac{e^{iz} - e^{-iz}}{2i} = \sum_{n=0}^{\infty} \frac{(-1)^n}{(2n+1)!} z^{2n+1}$$

and

$$\cos z = \frac{e^{iz} + e^{-iz}}{2} = \sum_{n=0}^{\infty} \frac{(-1)^n}{(2n)!} z^{2n}.$$

(7) Similarly,

$$\sinh z = \sum_{n=0}^{\infty} \frac{1}{(2n+1)!} z^{2n+1} \text{ and}$$

$$\cosh z = \sum_{n=0}^{\infty} \frac{1}{(2n)!} z^{2n}.$$

(8) Do  $\sin(z)$  centered at  $z_0$ . To do this again let  $z = z_0 + h$  and then

$$\sin(z) = \sin(z_0 + h) = \sin(z_0) \cos(h) + \cos(z_0) \sin(h)$$

$$= \sin(z_0) \sum_{n=0}^{\infty} \frac{(-1)^n}{(2n+1)!} (z - z_0)^{2n+1} + \cos(z_0) \sum_{n=0}^{\infty} \frac{(-1)^n}{(2n)!} (z - z_0)^{2n}.$$

(9) Consider the power series expansion of the function  $f(z) := \frac{1}{w-z}$  centered at  $z = z_0$  with  $z_0 \neq w$ . To do this again write  $z = z_0 + h \in \mathbb{C}$ , then

$$\begin{aligned} \frac{1}{w-z} &= \frac{1}{w-z_0-h} = \frac{1}{w-z_0} \frac{1}{1-h/(w-z_0)} \\ &= \frac{1}{w-z_0} \sum_{n=0}^{\infty} \left(\frac{h}{w-z_0}\right)^n = \sum_{n=0}^{\infty} \left(\frac{1}{w-z_0}\right)^{n+1} (z-z_0)^n \end{aligned}$$

provided that  $|h| = |z - z_0| < |w - z_0|$ , i.e.

$$(20.6) \quad \frac{1}{w-z} = \sum_{n=0}^{\infty} \left(\frac{1}{w-z_0}\right)^{n+1} (z-z_0)^n \text{ for } |z-z_0| < |w-z_0|.$$

We may now also differentiate this series in  $z$  to learn

$$\frac{1}{(w-z)^2} = \sum_{n=0}^{\infty} n \left(\frac{1}{w-z_0}\right)^{n+1} (z-z_0)^{n-1}$$

and again to learn

$$\frac{2}{(w-z)^3} = \sum_{n=0}^{\infty} n(n-1) \left(\frac{1}{w-z_0}\right)^{n+1} (z-z_0)^{n-2}$$

## 21. (11/21/2003) LECTURE 21

- Reviewed the general method of using the residue theorem for computing real integrals. So far we are restricted to computing residues only in simple contexts. This will be remedied in the next lecture.

**Example 21.1.** Suppose that  $f(z) = (1+z)^\alpha := e^{\alpha \text{Log}(1+z)}$ . Then

$$f'(z) = \alpha(1+z)^{\alpha-1}, \quad f''(z) = \alpha(\alpha-1)(1+z)^{\alpha-2}, \dots$$

$$f^{(n)}(z) = \alpha(\alpha-1)\dots(\alpha-n+1)(1+z)^{\alpha-n}$$

and therefore,

$$(1+z)^\alpha = \sum_{n=0}^{\infty} \frac{\alpha(\alpha-1)\dots(\alpha-n+1)}{n!} z^n.$$

For example if  $\alpha = -1$ , then

$$\alpha(\alpha-1)\dots(\alpha-n+1) = -1(-2)\dots(-n) = (-1)^n n!$$

and we find again that

$$\frac{1}{1+z} = \sum_{n=0}^{\infty} (-1)^n z^n.$$

Suppose that  $f$  is an analytic function near  $z = z_0$  and  $f(z_0) = 0$ . Then if  $f$  is not identically zero, there is a first  $n \in \mathbb{N}$  such that  $f^{(n)}(z_0) \neq 0$ , and therefore  $f$  has a power series expansion of the form

$$f(z) = \sum_{k=n}^{\infty} a_k (z-z_0)^k = (z-z_0)^n \sum_{k=n}^{\infty} a_k^{k-n} (z-z_0) = (z-z_0)^n g(z)$$

where  $g$  is analytic on the same set where  $f$  is analytic and  $g(z_0) \neq 0$ . In this case we say the  $f$  has a **zero of order  $n$  at  $z_0$** . Notice that if  $f$  has a zero of order  $\infty$  at  $z_0$  then  $f = 0$  near  $z_0$  and in fact  $f = 0$  on the connected component of  $\Omega$  containing  $z_0$ .

**Theorem 21.2** (Analytic Continuation). *Suppose that  $f : \Omega \rightarrow \mathbb{C}$  is an analytic function on a connected open subset  $\mathbb{C}$  such that  $Z(f) := \{z \in \Omega : f(z) = 0\}$  has an accumulation point in  $\Omega$ , then  $f \equiv 0$ .*

**Proof.** Suppose for simplicity  $0 \in \Omega$  and there exists  $z_n \in \Omega$  such that  $z_n \neq 0$  for all  $n$  and  $z_n \rightarrow 0$  as  $n \rightarrow \infty$ . Writing

$$f(z) = \sum_{n=0}^{\infty} a_n z^n,$$

we have  $0 = f(z_n) \rightarrow f(0) = a_0$ . Since

$$\frac{f(z)}{z} = \sum_{n=1}^{\infty} a_n z^{n-1}$$

we have  $0 = \frac{f(z_n)}{z_n} \rightarrow a_1$  showing  $a_1 = 0$ . Hence now we have

$$\frac{f(z)}{z^2} = \sum_{n=2}^{\infty} a_n z^{n-2}$$



and  $0 = \frac{f(z_n)}{z_n^2} \rightarrow a_2$  showing  $a_2 = 0$ . Continuing this way, we learn  $a_n = 0$  for all  $n$  and hence  $f(z) = 0$  near 0. Since  $\Omega$  is connected we may connect any point  $z \in \Omega$  by a path and then use the Picture in Figure 9 below to argue that  $f(z) = 0$ , i.e.  $f \equiv 0$ . ■

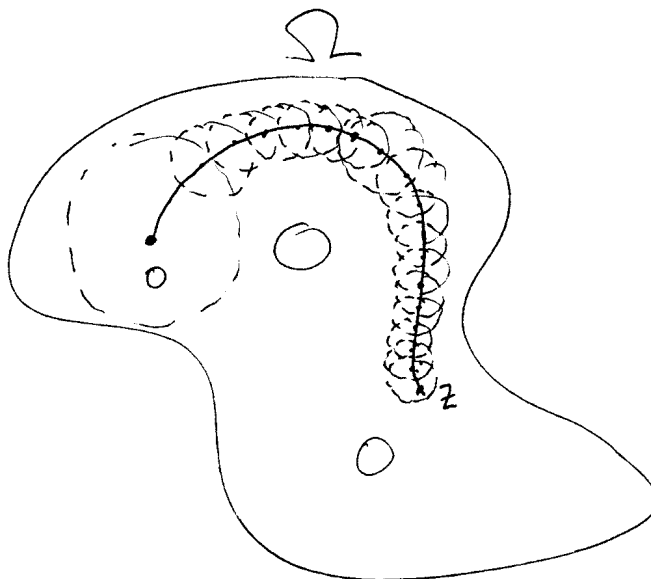

FIGURE 9. Stringing together a sequence of disks in order to show that if  $f = 0$  near one point in a connected region then  $f \equiv 0$ .

**Corollary 21.3.** *If  $f$  and  $g$  are two entire functions such that  $f = g$  on the real axis then  $f(z) = g(z)$  for all  $z \in \mathbb{C}$ . In particular if  $f(x)$  is a real valued function of  $x \in \mathbb{R}$ , there is at most one extension of  $f$  to an analytic function on  $\mathbb{C}$ .*

**Proof.** Apply the previous theorem to  $f - g$ . ■

**Example 21.4.** Suppose we wish to verify that

$$(21.1) \quad \sin(z + w) = \sin z \cos w + \cos z \sin w$$

using only the statement for real  $z$  and  $w$ . To do this, first assume that  $w$  is real, then both sides of Eq. (21.1) are analytic in  $z$  and agree for  $z$  real and therefore are equal for all  $z \in \mathbb{C}$ . Hence we now know that Eq. (21.1) holds for  $w \in \mathbb{R}$  and  $z \in \mathbb{C}$ . Now fix  $z \in \mathbb{C}$ , then both sides of Eq. (21.1) are analytic in  $w$  and agree for  $w$  real and therefore are equal for all  $w \in \mathbb{C}$ .

## 22. (11/24/2003) LECTURE 22

22.1. **Laurent Series and Residues.** For  $z_0 \in \mathbb{C}$  and  $0 \leq r < R \leq \infty$ , let

$$A(z_0, r, R) := \{z \in \mathbb{C} : r < |z - z_0| < R\}$$

so that  $A(z_0, r, R)$  is an annulus centered at  $z_0$ .

**Theorem 22.1** (Laurent Series). *Suppose that  $f : A(z_0, r, R) \rightarrow \mathbb{C}$  is analytic and let*

$$(22.1) \quad a_n = \frac{1}{2\pi i} \oint_{C_\rho} \frac{f(z)}{(z - z_0)^{n+1}} dz.$$

where  $C_\rho(\theta) := z_0 + \rho e^{i\theta}$  for  $\theta : 0 \rightarrow 2\pi$  and  $r < \rho < R$ . Then

$$(22.2) \quad f(z) = \sum_{n=-\infty}^{\infty} a_n (z - z_0)^n \text{ for all } z \in A(z_0, r, R)$$

where the above **Laurent series** converges absolutely.

**Proof.** (Only Sketched in Class.) First suppose that  $z_0 = 0$  and let  $z \in A(0, r, R)$ . Choose  $r_0$  and  $R_0$  such that  $r < r_0 < |z| < R_0 < R$ . In this case the Cauchy integral formula may be written as

$$(22.3) \quad f(z) = \frac{1}{2\pi i} \left[ \oint_{C_{R_0}} \frac{f(w)}{(w - z)} dw - \oint_{C_{r_0}} \frac{f(w)}{(w - z)} dw \right],$$

see Figure 10.

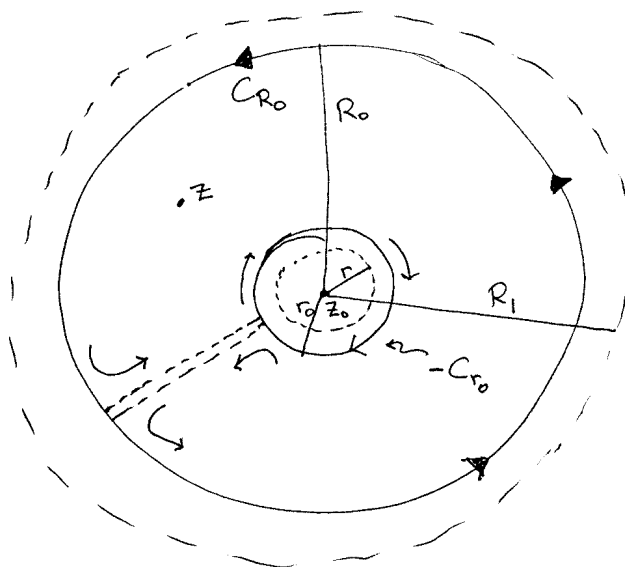

FIGURE 10. Setting up to use the Cauchy integral formula.

For  $w \in C_{R_0}$  we have

$$\frac{1}{w-z} = \frac{1}{w} \frac{1}{1-z/w} = \frac{1}{w} \sum_{n=0}^{\infty} \left(\frac{z}{w}\right)^n$$

and hence applying Theorem 20.1 we find

$$\frac{1}{2\pi i} \oint_{C_{R_0}} \frac{f(w)}{(w-z)} dw = \sum_{n=0}^{\infty} \left[ \frac{1}{2\pi i} \oint_{|w|=R_0} \frac{f(w)}{w^{n+1}} dw \right] z^n.$$

By Cauchy Goursat theorem,

$$\frac{1}{2\pi i} \oint_{|w|=R_0} \frac{f(w)}{w^{n+1}} dw = \frac{1}{2\pi i} \oint_{|w|=\rho} \frac{f(w)}{w^{n+1}} dw = a_n$$

and so

$$(22.4) \quad \frac{1}{2\pi i} \oint_{C_{R_0}} \frac{f(w)}{(w-z)} dw = \sum_{n=0}^{\infty} a_n z^n.$$

Similarly for  $w \in C_{r_0}$ ,

$$-\frac{1}{w-z} = \frac{1}{z} \frac{1}{1-w/z} = \frac{1}{z} \sum_{n=0}^{\infty} \left(\frac{w}{z}\right)^n$$

and hence applying Theorem 20.1,

$$\begin{aligned} -\frac{1}{2\pi i} \oint_{C_{r_0}} \frac{f(w)}{(w-z)} dw &= \sum_{n=0}^{\infty} \left[ \frac{1}{2\pi i} \oint_{C_{r_0}} f(w) w^n dw \right] z^{-(n+1)} \\ &= \sum_{n=0}^{\infty} \left[ \frac{1}{2\pi i} \oint_{C_\rho} \frac{f(w)}{w^{-n}} dw \right] z^{-(n+1)} \end{aligned}$$

where we have used the Cauchy Goursat theorem in the last equality. Finally letting  $k = -(n+1)$  or  $-n = k+1$  in the previous sum gives

$$(22.5) \quad -\frac{1}{2\pi i} \oint_{C_{r_0}} \frac{f(w)}{(w-z)} dw = \sum_{k=-\infty}^{-1} \left[ \frac{1}{2\pi i} \oint_{C_\rho} \frac{f(w)}{w^{k+1}} dw \right] z^k = \sum_{k=-\infty}^{-1} a_k z^k.$$

Combining Eqs. (22.3), (22.4) and (22.5) verifies Eq. (22.2) when  $z_0 = 0$ .

When  $z_0 \neq 0$ , apply what we have just proved to  $g(h) = f(z_0 + h)$  with  $h = (z - z_0)$  to learn

$$f(z) = g(h) = \sum_{n=-\infty}^{\infty} a_n h^n = \sum_{n=-\infty}^{\infty} a_n (z - z_0)^n$$

where

$$a_n := \frac{1}{2\pi i} \oint_{|w|=\rho} \frac{g(w)}{w^{n+1}} dw = \frac{1}{2\pi i} \oint_{|w|=\rho} \frac{f(z_0 + w)}{w^{n+1}} dw.$$

Finally make the change of variables,  $z = z_0 + w$  in the previous integral to learn

$$a_n = \frac{1}{2\pi i} \oint_{|z-z_0|=\rho} \frac{f(z)}{(z-z_0)^{n+1}} dz.$$

■

**Definition 22.2.** An analytic function  $f$  on  $\Omega \setminus \{z_0\}$  is said to have an **isolated singularity** at  $z_0$ . Let

$$f(z) = \sum_{n=-\infty}^{\infty} a_n (z - z_0)^n \text{ for } 0 < |z - z_0| < R$$

be the Laurent series expansion of  $f$  centered at  $z_0$ . The portion of this sum:

$$\sum_{n=-\infty}^{-1} a_n (z - z_0)^n$$

is called **principle part** of  $f$  near  $z_0$ .

- (1)  $f$  has an **essential singularity** at  $z_0$  if  $\#\{n < 0 : a_n \neq 0\} = \infty$ .
- (2)  $f$  has a **removable singularity** at  $z_0$  if  $\#\{n < 0 : a_n \neq 0\} = 0$ , i.e. if the principle part is 0.
- (3)  $f$  has a **pole of order  $N$**  if the principle part of  $f$  at  $z_0$  is of the form

$$\sum_{n=-N}^{-1} a_n (z - z_0)^n \text{ with } a_{-N} \neq 0.$$

If  $N = 1$ ,  $f$  is said to have a **simple pole** at  $z_0$ .

*Remark 22.3.* If  $f$  has an isolated singularity at  $z_0$ , then by Eq. (22.1)

$$\text{res}_{z_0} f = a_{-1}.$$

**Example 22.4.**

- (1)  $e^{1/z} = \sum_{n=0}^{\infty} \frac{1}{n!} z^{-n}$ ,  $\text{res}_0 (e^{1/z}) = 1$  and  $z = 0$  is an essential singularity point. Mention consequences for integrals.
- (2) Since

$$\begin{aligned} \frac{\sin z}{z^3} &= \frac{1}{z^3} \left( z - \frac{z^3}{3!} + \frac{z^5}{5!} - \dots \right) \\ &= z^{-2} - \frac{1}{3!} + \frac{z^2}{5!} - \dots, \end{aligned}$$

$\text{res}_0 \left[ \frac{\sin z}{z^3} \right] = 0$  and there is a pole of order 2 at 0.

(3)

$$\begin{aligned} \frac{\cos z}{z^3} &= \frac{1}{z^3} \left( 1 - \frac{z^2}{2!} + \frac{z^4}{4!} - \dots \right) \\ &= z^{-3} - \frac{z^{-1}}{2!} + \frac{z}{4!} - \dots \end{aligned}$$

so that  $\text{res}_0 \left[ \frac{\cos z}{z^3} \right] = -\frac{1}{2}$ .

- (4) Use partial fractions to find the Laurent series expansions of

$$f(z) := \frac{1}{(z-1)(z-2)} \text{ at } z_0 = 0$$

in the three regions:  $|z| < 1$ ,  $1 < |z| < 2$  and  $|z| > 2$ . To do this write

$$\frac{1}{(z-1)(z-2)} = \frac{A}{z-1} + \frac{B}{z-2}$$

and multiply by  $(z - 1)(z - 2)$  to find

$$1 = A(z - 2) + B(z - 1).$$

Evaluating at  $z = 1$  and  $z = 2$  then implies that  $A = -1$  and  $B = 1$  so that

$$\frac{1}{(z - 1)(z - 2)} = \frac{-1}{z - 1} + \frac{1}{z - 2}.$$

(a) For  $|z| < 1$ , we have

$$\begin{aligned} f(z) &= \frac{1}{1 - z} - \frac{1}{2} \frac{1}{1 - z/2} \\ &= \sum_{n=0}^{\infty} \left[ z^n - \frac{1}{2} \left( \frac{z}{2} \right)^n \right] = \sum_{n=0}^{\infty} \left[ 1 - \frac{1}{2^n} \right] z^n. \end{aligned}$$

(b) For  $1 < |z| < 2$ , we have

$$\begin{aligned} f(z) &= -\frac{1}{z} \frac{1}{1 - 1/z} - \frac{1}{2} \frac{1}{1 - z/2} \\ &= -\frac{1}{z} \sum_{n=0}^{\infty} z^{-n} - \frac{1}{2} \sum_{n=0}^{\infty} \left( \frac{z}{2} \right)^n \\ &= -\sum_{n=0}^{\infty} z^{-n-1} - \frac{1}{2} \sum_{n=0}^{\infty} \left( \frac{z}{2} \right)^n. \end{aligned}$$

(c) For  $|z| > 2$ , we have

$$\begin{aligned} f(z) &= -\frac{1}{z} \frac{1}{1 - 1/z} + \frac{1}{z} \frac{1}{1 - 2/z} \\ &= -\sum_{n=0}^{\infty} z^{-n-1} + \frac{1}{z} \sum_{n=0}^{\infty} \left( \frac{2}{z} \right)^n \\ &= \sum_{n=0}^{\infty} (2^n - 1) z^{-n-1}. \end{aligned}$$

## 23. (11/26/2003) LECTURE 23

**Proposition 23.1.** *Suppose  $f(z)$  is analytic on  $D'(z_0, \varepsilon)$  and*

$$(23.1) \quad f(z) = \sum_{n=-K}^N a_n (z - z_0)^n + O\left((z - z_0)^{N+1}\right),$$

then

$$a_n = \frac{1}{2\pi i} \oint_{|z-z_0|=\rho} \frac{f(z)}{(z-z_0)^{n+1}} dz \text{ with } 0 < \rho < \varepsilon$$

are the Laurent coefficients of  $f$  for  $n = -K, \dots, N$ . In particular if  $f$  is analytic on  $D'(z_0, \varepsilon)$  and

$$(23.2) \quad f(z) = \sum_{n=0}^N a_n^n (z - z_0) + O\left((z - z_0)^{N+1}\right),$$

then  $a_n = \frac{f^{(n)}(z_0)}{n!}$  for  $n \leq N$ .

**Proof.** For simplicity of notation let us assume that  $z_0 = 0$ . Using

$$\frac{1}{2\pi i} \oint_{|z|=\rho} \frac{1}{w^n} dw = \begin{cases} 0 & \text{if } n \neq 1 \\ 1 & \text{if } n = 1, \end{cases}$$

$$\begin{aligned} \frac{1}{2\pi i} \oint_{|z|=\rho} \frac{f(z)}{z^{k+1}} dz &= \frac{1}{2\pi i} \oint_{|z|=\rho} \frac{1}{z^{k+1}} \left( \sum_{n=-K}^N a_n z^n + O(z^{N+1}) \right) dz \\ &= \frac{1}{2\pi i} \oint_{|z|=\rho} \frac{1}{z^{k+1}} \left( \sum_{n=-K}^N a_n z^n + O(z^{N+1}) \right) dz \\ &= a_k + \frac{1}{2\pi i} \oint_{|z|=\rho} O(z^{N-k}) dz \end{aligned}$$

which gives the result, since

$$\left| \frac{1}{2\pi i} \oint_{|z|=\rho} O(z^{N-k}) dz \right| \leq \left| \frac{1}{2\pi} O(\rho^{N-k}) \right| 2\pi\rho \rightarrow 0 \text{ as } \rho \rightarrow 0$$

provided  $N \geq k$ . The second assertion follows from the first using

$$f^{(n)}(0) = \frac{n!}{2\pi i} \oint_{|z|=\rho} \frac{f(z)}{z^{n+1}} dz \text{ for } n \geq 0.$$

Here is a **second proof** of the **second assertion**. We have

$$\sum_{n=0}^N a_n z^n + O(z^{N+1}) = f(z) = \sum_{n=0}^{\infty} \frac{f^{(n)}(0)}{n!} z^n$$

and therefore,

$$\sum_{n=0}^N \left[ \frac{f^{(n)}(0)}{n!} - a_n \right] z^n = O(z^{N+1}) - z^{N+1} \sum_{n=N+1}^{\infty} \frac{f^{(n)}(0)}{n!} z^{n-N-1} = O(z^{N+1}).$$

Taking  $z = 0$  shows  $\frac{f^{(0)}(0)}{0!} - a_0 = 0$  and then working inductively we learn  $a_n = \frac{f^{(n)}(0)}{n!}$  for all  $n \leq N$ . ■

*Remark 23.2.* In working the following examples we will make use of the following basic power series:

- (1)  $(1+z)^\alpha = \sum_{n=0}^\infty \frac{\alpha(\alpha-1)\dots(\alpha-n+1)}{n!} z^n$  so that
 
$$(1+z)^\alpha = 1 + \alpha z + \frac{\alpha(\alpha-1)}{2!} z^2 + \frac{\alpha(\alpha-1)(\alpha-2)}{3!} z^3 + \dots$$
- (2)  $e^z = \sum_{n=0}^\infty \frac{1}{n!} z^n$
- (3)  $\sin z = \sum_{n=0}^\infty \frac{(-1)^n}{(2n+1)!} z^{2n+1}$
- (4)  $\cos z = \sum_{n=0}^\infty \frac{(-1)^n}{(2n)!} z^{2n}$
- (5)  $\sinh z = \sum_{n=0}^\infty \frac{1}{(2n+1)!} z^{2n+1}$
- (6)  $\cosh z = \sum_{n=0}^\infty \frac{1}{(2n)!} z^{2n}$ .

**Example 23.3.** #1 on p. 238. Find the order  $m$  and residue  $B$  of the poles of the following functions

- 1)  $\frac{z^2+2}{z-1}$ ,      2)  $\left(\frac{z}{2z+1}\right)^3$ ,      3)  $\frac{e^z}{z^2+\pi^2}$       4)  $\frac{e^z}{(z^2+1)^2}$
- 5)  $\frac{1}{\sin(z^2)}$ ,      6)  $\frac{e^z}{\sin^2(z)}$  at  $z = \pi$

(1) Let  $z = 1 + h$ , then

$$\frac{z^2+2}{z-1} = \frac{(1+h)^2+2}{h} = \frac{3+2h+h^2}{h}$$

so  $m = 1$  and  $B = 3$ . Alternatively,  $\text{res}_1\left(\frac{z^2+2}{z-1}\right) = \frac{1^2+2}{1} = 3$ .

(2) Let  $z = -\frac{1}{2} + h$ , then

$$\left(\frac{z}{2z+1}\right)^3 = \left(\frac{-\frac{1}{2}+h}{2h}\right)^3 = \frac{1}{8h^3} \left(-\frac{1}{2}+h\right)^3 = \frac{1}{8h^3} \left(-\frac{1}{8} + \frac{3}{4}h - \frac{3}{2}h^2 + h^3\right)$$

so that  $m = 3$  and  $B = -\frac{3}{16}$ .

(3) The poles is at  $\pm i\pi$  and is of order 1 and we have

$$\text{res}_{\pm i\pi} \frac{e^{\pm i\pi}}{2(\pm i\pi)} = \pm \frac{i}{2\pi}.$$

(4) The poles are at  $\pm i$  and  $m = 2$ . Let  $z = i + h$  to find

$$\begin{aligned} \frac{e^z}{(z^2+1)^2} &= \frac{e^z}{(z+i)^2(z-i)^2} = \frac{e^{i+h}}{(2i+h)^2 h^2} = \frac{e^i}{-4} \frac{1}{h^2} e^h (1+h/2i)^{-2} \\ &= \frac{e^i}{-4} \frac{1}{h^2} (1+h+O(h^2))(1-2h/2i+O(h^2)) \\ &= \frac{e^i}{-4} \frac{1}{h^2} (1+h+O(h^2))(1+ih+O(h^2)) \\ &= \left(\dots + \frac{e^i}{-4} (i+1) h^{-1} + \dots\right) \end{aligned}$$

and so

$$\text{res}_i \frac{e^z}{(z^2+1)^2} = -\frac{e^i}{4} (i+1).$$

(5) This function has poles at  $z^2 = n\pi$  or  $z = (n\pi)^{1/2}$ . Let  $z_0 \in (n\pi)^{1/2}$  and  $z = z_0 + h$ . Then

$$\begin{aligned}\sin(z^2) &= \sin(z_0^2 + 2z_0h + h^2) = \sin(n\pi + 2z_0h + h^2) \\ &= \sin(n\pi) \cos(2z_0h + h^2) + \cos(n\pi) \sin(2z_0h + h^2) \\ &= (-1)^n (2z_0h + O(h^2))\end{aligned}$$

where we assume that  $n \neq 0$  for the moment. Then

$$\begin{aligned}\frac{1}{\sin(z^2)} &= \frac{1}{(-1)^n (2z_0h + O(h^2))} = \frac{(-1)^n}{2z_0h} \frac{1}{1 + O(h)} \\ &= \frac{(-1)^n}{2z_0h} (1 + O(h))\end{aligned}$$

and so

$$\operatorname{res}_{(n\pi)^{1/2}} \frac{1}{\sin(z^2)} = \frac{(-1)^n}{2(n\pi)^{1/2}} \text{ if } n \neq 0.$$

This can be done by our old friend as well, namely,

$$\operatorname{res}_{(n\pi)^{1/2}} \frac{1}{\sin(z^2)} = \frac{1}{2z \cos(z^2)} \Big|_{z=(n\pi)^{1/2}} = \frac{(-1)^n}{2(n\pi)^{1/2}}.$$

For  $n = 0$ , we have again that

$$\sin(z^2) = z^2 - \frac{z^6}{6} + O(z^{10})$$

so that

$$\frac{1}{\sin(z^2)} = \frac{1}{z^2 - \frac{z^6}{6} + O(z^{10})} = \frac{1}{z^2} \frac{1}{1 - \frac{z^4}{6} + O(z^8)} = \frac{1}{z^2} (1 + O(z^4))$$

and so

$$\operatorname{res}_0 \frac{1}{\sin(z^2)} = 0.$$



## 24. (12/1/2003) LECTURE 24

**Example 24.1.** (Skipped.) The function  $\frac{e^z}{\sin^2(z)}$  at  $z = \pi$  has a pole of order 2 since  $\sin^2(z)$  has a zero of order two there. So again let  $z = \pi + h$  and use

$$\sin(z) = \sin(\pi + h) = -\sin(h)$$

so that

$$\begin{aligned} \frac{e^z}{\sin^2(z)} &= \frac{e^{\pi+h}}{\sin^2(\pi+h)} = e^\pi \frac{\left(1 + h + \frac{h^2}{2!} + \dots\right)}{\sin^2(h)} \\ &= e^\pi \frac{\left(1 + h + \frac{h^2}{2!} + \dots\right)}{\left(h - \frac{h^3}{3!} + \dots\right)^2} = \frac{e^\pi \left(1 + h + \frac{h^2}{2!} + \dots\right)}{h^2 \left(1 - \frac{h^2}{3!} + \dots\right)^2} \\ &= \frac{e^\pi}{h^2} \left(1 + h + O(h^2)\right) \left(1 + O(h^2)\right) \end{aligned}$$

and so

$$\operatorname{res}_\pi \frac{e^z}{\sin^2(z)} = e^\pi.$$

**Example 24.2.** (Skipped.) Find the first few terms in the Taylor series expansion of  $\frac{1}{1-z} \cos z$  and  $\frac{1}{1-z} \frac{1}{\cos z}$ . To do this we have

$$\begin{aligned} \frac{1}{1-z} \cos z &= \left(1 + z + z^2 + z^3 + O(z^4)\right) \left(1 - \frac{z^2}{2!} + O(z^4)\right) \\ &= 1 - \frac{z^2}{2!} + z - \frac{z^3}{2!} + z^2 + z^3 + O(z^4) = 1 + z + \frac{z^2}{2} + \frac{z^3}{2} + O(z^4) \end{aligned}$$

and similarly,

$$\begin{aligned} \frac{1}{1-z} \frac{1}{\cos z} &= \left(1 + z + z^2 + z^3 + O(z^4)\right) \frac{1}{\left(1 - \frac{z^2}{2!} + O(z^4)\right)} \\ &= \left(1 + z + z^2 + z^3 + O(z^4)\right) \left(1 + \frac{z^2}{2!} + O(z^4)\right) \\ &= 1 + \frac{z^2}{2!} + z + \frac{z^3}{2!} + z^2 + z^3 + O(z^4) \\ &= 1 + z + \frac{3}{2}z^2 + \frac{3}{2}z^3 + O(z^4). \end{aligned}$$

**Example 24.3.** (Skipped.) Now consider

$$\begin{aligned} \frac{1}{1-z} \frac{1}{\sin z} &= \frac{1}{1-z} \frac{1}{\left(z - \frac{z^3}{3!} + O(z^5)\right)} \\ &= \frac{1}{z} \frac{1}{\left(1 - \frac{z^2}{3!} + O(z^4)\right)} \left(1 + z + z^2 + z^3 + O(z^4)\right) \\ &= \frac{1}{z} \left(1 + \frac{z^2}{3!} + O(z^4)\right) \left(1 + z + z^2 + z^3 + O(z^4)\right) \\ &= \frac{1}{z} \left(1 + z + z^2 + z^3 + \frac{z^2}{3!} + \frac{z^3}{3!} + O(z^4)\right) \\ &= \frac{1}{z} + 1 + \frac{7}{6}(z + z^2) + O(z^3). \end{aligned}$$

**Example 24.4.** (Skipped.) Show

$$\operatorname{res}_{z=0} \frac{e^z}{z \sin z} = \operatorname{res}_{z=0} \frac{e^z}{\sin^2 z} = 0.$$

To do this we have

$$\begin{aligned} \sin^2 z &= (z - z^3/3! + O(z^5))^2 = (z - z^3/3! + O(z^5))(z - z^3/3! + O(z^5)) \\ &= z^2 + O(z^4) = z^2(1 + O(z^2)) \end{aligned}$$

and therefore

$$\frac{1}{\sin^2 z} = \frac{1}{z^2(1 + O(z^2))} = \frac{1}{z^2}(1 + O(z^2)) = z^{-2} + O(1).$$

Therefore

$$\frac{e^z}{\sin^2 z} = (z^{-2} + O(1))(1 + O(z^2)) = z^{-2} + O(1)$$

Similarly

$$z \sin z = z(z - z^3/3! + O(z^5)) = z^2(1 + O(z^2))$$

and so the residue is the same.

**Example 24.5.** Show

$$\oint_{|z|=1} \frac{e^z}{z \sin^2 z} dz = 2\pi i \cdot \operatorname{res}_{z=0} \frac{e^z}{z \sin^3 z} = 2\pi i \frac{5}{6} = \frac{5}{3}\pi i.$$

To do this we have

$$\begin{aligned} z \sin^2 z &= (z - z^3/3! + O(z^5))^2 = z(z - z^3/3! + O(z^5))(z - z^3/3! + O(z^5)) \\ &= z(z^2 - 2z^4/3! + O(z^5)) \\ &= z^3 - \frac{1}{3}z^5 + O(z^6) = z^3 \left(1 - \frac{1}{3}z^2 + O(z^3)\right) \end{aligned}$$

and hence

$$\begin{aligned} \frac{1}{z \sin^2 z} &= \frac{1}{z^3(1 - \frac{1}{3}z^2 + O(z^3))} \\ &= \frac{1}{z^3} \left(1 + \frac{1}{3}z^2 + O(z^3) + \left(\frac{1}{3}z^2 + O(z^3)\right)^2\right) \\ &= z^{-3} + \frac{1}{3}z^{-1} + O(1). \end{aligned}$$

Hence

$$\begin{aligned} \frac{1}{z \sin^2 z} e^z &= \left[z^{-3} + \frac{1}{3}z^{-1} + O(1)\right] [1 + z + z^2/2 + O(z^3)] \\ &= \dots \left(\frac{1}{3} + \frac{1}{2}\right) z^{-1} + \dots \end{aligned}$$

and

$$\operatorname{res}_{z=0} \frac{e^z}{z \sin^3 z} = \frac{5}{6}$$

**Example 24.6.** #4 p. 219,

$$\oint_{|z|=1} \frac{1}{z^2 \sinh z} dz = -\frac{\pi i}{3}$$

To see this we need to compute the residue at 0. For this we have

$$\begin{aligned} \frac{1}{z^2 \sinh z} &= \frac{1}{z^2 \left( z + \frac{z^3}{3!} + \frac{z^5}{5!} + \dots \right)} = \frac{1}{z^3} \frac{1}{1 + \frac{z^2}{3!} + \frac{z^5}{5!} + \dots} \\ &= \frac{1}{z^3} \left( 1 - \left( \frac{z^2}{3!} - \frac{z^5}{5!} + \dots \right) + \left( \frac{z^2}{3!} - \frac{z^5}{5!} + \dots \right)^2 + \dots \right) \\ &= \frac{1}{z^3} \left( 1 - \frac{z^2}{3!} + \dots \right) \end{aligned}$$

from which it follows that

$$\operatorname{res}_{z=0} \frac{1}{z^2 \sinh z} = -\frac{1}{6}$$

and this gives the answer.

**Example 24.7.** Compute the integral ( $a > 0$ )

$$\begin{aligned} \int_{-\infty}^{\infty} \frac{x \sin ax}{(1+x^2)^2} dx &= \operatorname{Im} \int_{-\infty}^{\infty} \frac{x e^{iax}}{(1+x^2)^2} dx \\ &= \operatorname{Im} \left[ 2\pi i \operatorname{res}_{z=i} \frac{z e^{iaz}}{(1+z^2)^2} \right] = \frac{\pi}{2} a e^{-a}. \end{aligned}$$

To compute this residue, let  $z = i + h$  and

$$f(z) := \frac{z e^{iaz}}{(1+z^2)^2} = \frac{z e^{iaz}}{(z-i)^2 (z+i)^2}$$

then

$$\begin{aligned} f(i+h) &= \frac{(i+h) e^{ia(i+h)}}{h^2 (h+2i)^2} = \frac{e^{-a}}{h^2} \frac{(i+h) e^{iah}}{-4(1-ih/2)^2} \\ &= \frac{e^{-a}}{-4h^2} \frac{(i+h) e^{iah}}{1-ih+O(h^2)} \\ &= \frac{e^{-a}}{-4h^2} (i+h) (1+iah+O(h^2)) (1+ih+O(h^2)) \\ &= \frac{e^{-a}}{-4h^2} (\dots + (1-a-1)h + \dots) \end{aligned}$$

and so

$$\operatorname{res}_{z=i} \frac{z e^{iaz}}{(1+z^2)^2} = \frac{a e^{-a}}{4}.$$

**Example 24.8** (Summing  $(-1)^{n+1}/n^2$ ). (Sketched only very briefly!!) S69, p. 245-246: #5. Let  $C_N$  be the counter clockwise oriented boundary of the square

$$Q_N := \left\{ z \in \mathbb{C} : |\operatorname{Re} z| \leq \left( N + \frac{1}{2} \right) \pi \text{ and } |\operatorname{Im} z| \leq \left( N + \frac{1}{2} \right) \pi \right\}$$

as in Figure 24.8. Then

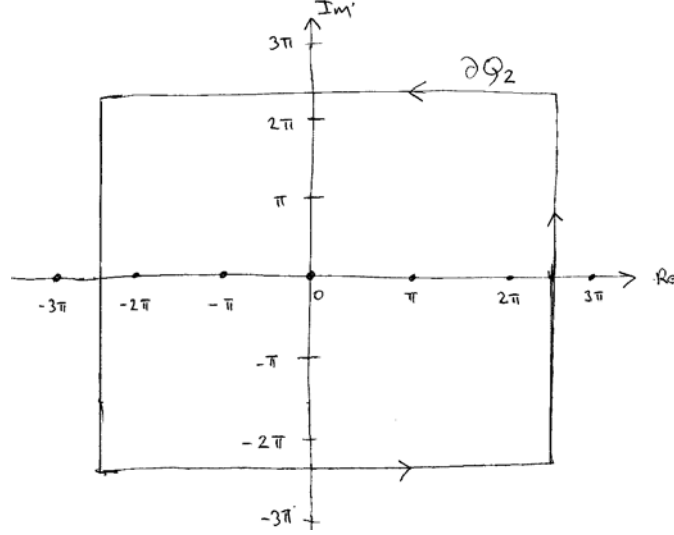

$$(24.1) \quad \lim_{N \rightarrow \infty} \int_{\partial Q_N} \frac{1}{z^2 \sin z} dz = 0$$

and

$$(24.2) \quad \int_{\partial Q_N} \frac{1}{z^2 \sin z} dz = 2\pi i \left[ \frac{1}{6} + \frac{2}{\pi^2} \sum_{n=1}^N \frac{(-1)^n}{n^2} \right]$$

from which it follows that

$$(24.3) \quad \sum_{n=1}^{\infty} \frac{(-1)^{n+1}}{n^2} = \frac{\pi^2}{12}.$$

To prove Eq. (24.1), on the part of the contours,  $x = \pm (N + \frac{1}{2}) \pi$  we have

$$\begin{aligned} \left| \sin \left( \pm \left( N + \frac{1}{2} \right) \pi + iy \right) \right| &= \left| \sin \left( \pm \left( N + \frac{1}{2} \right) \pi \right) \cos(iy) + \cos \left( \pm \left( N + \frac{1}{2} \right) \pi \right) \sin(iy) \right| \\ &= |\pm \cosh y| \geq 1 \end{aligned}$$

and on the part of the contours,

$$y = \pm \left( N + \frac{1}{2} \right) \pi$$

we have

$$\begin{aligned} \left| \sin \left( x \pm i \left( N + \frac{1}{2} \right) \pi \right) \right| &= \left| \sin(x) \cos \left( \pm i \left( N + \frac{1}{2} \right) \pi \right) + \cos(x) \sin \left( \pm i \left( N + \frac{1}{2} \right) \pi \right) \right| \\ &= \left| \sin(x) \cosh \left( \left( N + \frac{1}{2} \right) \pi \right) \pm i \cos(x) \sinh \left( \left( N + \frac{1}{2} \right) \pi \right) \right| \\ &\cong e^{(N+\frac{1}{2})\pi} \geq 1. \end{aligned}$$

Hence we have on the contour that

$$\left| \frac{1}{z^2 \sin z} \right| \leq \frac{1}{(N + \frac{1}{2})^2 \pi^2}$$

and therefore,

$$\left| \int_{\partial Q_N} \frac{1}{z^2 \sin z} dz \right| \leq \frac{1}{(N + \frac{1}{2})^2 \pi^2} 4(2N + 1) \rightarrow 0 \text{ as } N \rightarrow \infty.$$

We now must compute the residues,

$$\begin{aligned} \frac{1}{z^2 \sin z} &= \frac{1}{z^2 \left( z - \frac{z^3}{3!} + \frac{z^5}{5!} + \dots \right)} = \frac{1}{z^3} \frac{1}{1 - \frac{z^2}{3!} + \frac{z^5}{5!} + \dots} \\ &= \frac{1}{z^3} \left( 1 + \left( \frac{z^2}{3!} - \frac{z^5}{5!} + \dots \right) + \left( \frac{z^2}{3!} - \frac{z^5}{5!} + \dots \right)^2 + \dots \right) \\ &= \frac{1}{z^3} \left( 1 + \frac{z^2}{3!} + \dots \right) \end{aligned}$$

so that

$$\text{res}_0 \frac{1}{z^2 \sin z} = \frac{1}{6}$$

while

$$\text{res}_{\pm n\pi} \frac{1}{z^2 \sin z} = \frac{1}{n^2 \pi^2 \cos(\pm n\pi)} = (-1)^n \frac{1}{n^2 \pi^2}$$

and therefore,

$$\begin{aligned} \int_{\partial Q_N} \frac{1}{z^2 \sin z} dz &= 2\pi i \left[ \frac{1}{6} + \sum_{n=\pm 1}^{\pm N} (-1)^n \frac{1}{n^2 \pi^2} \right] \\ &= 2\pi i \left[ \frac{1}{6} + \frac{2}{\pi^2} \sum_{n=1}^N \frac{(-1)^n}{n^2} \right]. \end{aligned}$$

**Example 24.9** (Bessel function relationship). (Skipped) #4 on p.230 (see also #10 on p. 199 )

$$\begin{aligned} \oint_{|z|=1} e^{(z+\frac{1}{z})} dz &= \oint_{|z|=1} \sum_{n=0}^{\infty} e^{\frac{1}{z}} \frac{z^n}{n!} dz = \sum_{n=0}^{\infty} \oint_{|z|=1} e^{\frac{1}{z}} \frac{z^n}{n!} dz \\ &= 2\pi i \sum_{n=0}^{\infty} \frac{1}{n!} \text{res}_0 \left[ e^{\frac{1}{z}} z^n \right] = 2\pi i \sum_{n=0}^{\infty} \frac{1}{n!} \frac{1}{(n+1)!}. \end{aligned}$$

Recall that Bessel functions may be defined by

$$e^{\frac{z}{2}(w-\frac{1}{w})} = \sum_{n=-\infty}^{\infty} J_n(z) w^n$$

and so

$$\begin{aligned}
 J_m(z) &= \frac{1}{2\pi i} \int_{|w|=1} \left( \sum_{n=-\infty}^{\infty} J_n(z) w^n \right) w^{-(m+1)} dw \\
 &= \frac{1}{2\pi i} \int_{|w|=1} e^{\frac{z}{2}\left(w - \frac{1}{w}\right)} w^{-(m+1)} dw \\
 &= \frac{1}{2\pi i} \int_{|w|=1} e^{\frac{z}{2w}} \sum_{n=0}^{\infty} \frac{1}{n!} \left(\frac{z}{2}\right)^n w^n w^{-(m+1)} dw \\
 &= \sum_{n=0}^{\infty} \frac{1}{n!} \left(\frac{z}{2}\right)^n \frac{1}{2\pi i} \int_{|w|=1} e^{\frac{z}{2w}} w^{n-m-1} dw \\
 &= \sum_{n=0}^{\infty} \frac{1}{n!} \left(\frac{z}{2}\right)^n \operatorname{res}_{w=0} [e^{\frac{z}{2w}} w^{n-m-1}] \\
 &= \sum_{n=0}^{\infty} \frac{1}{n!} \left(\frac{z}{2}\right)^n \frac{1}{m!} \left(\frac{z}{2}\right)^m = \sum_{n=0}^{\infty} \frac{1}{n!m!} \left(\frac{z}{2}\right)^{m+n}.
 \end{aligned}$$

Writing out the contour integral explicitly we also

$$\begin{aligned}
 J_m(z) &= \frac{1}{2\pi} \int_{-\pi}^{\pi} e^{\frac{z}{2}(e^{i\theta} - e^{-i\theta})} e^{-i(m+1)\theta} e^{i\theta} d\theta \\
 &= \frac{1}{2\pi} \int_{-\pi}^{\pi} e^{iz \sin \theta} e^{-im\theta} d\theta \\
 &= \frac{1}{2\pi} \int_{-\pi}^{\pi} e^{-i[m\theta - z \sin \theta]} d\theta \\
 &= \frac{1}{2\pi} \int_{-\pi}^{\pi} \cos(m\theta - z \sin \theta) d\theta.
 \end{aligned}$$

## 25. (12/3/2003) LECTURE 25: MORE CONTOUR INTEGRALS

**Example 25.1** (ex.abc). To evaluate sums of the form

$$\sum_{n=1}^{\infty} \frac{p(n)}{q(n)} \quad \text{and} \quad \sum_{n=1}^{\infty} (-1)^n \frac{p(n)}{q(n)}$$

where  $p$  and  $q$  are two polynomials with  $\deg q \geq \deg p + 2$ , one should consider the integrals

$$\lim_{N \rightarrow \infty} \int_{\partial Q_N} \frac{p(z)}{q(z)} \cot \pi z \, dz \quad \text{and} \quad \lim_{N \rightarrow \infty} \int_{\partial Q_N} \frac{p(z)}{q(z)} \csc \pi z \, dz$$

where  $\partial Q_N$  is as in Example 24.8. See Problem 18 on p. 163 of Berenstein and Gay, “Complex Variables: An introduction.”

**Example 25.2.** We wish to show

$$I = \int_0^{2\pi} \frac{\cos \theta}{5 + 4 \cos \theta} d\theta = -\frac{\pi}{3}.$$

(Maple gives  $\frac{\pi}{2}$  which seems to be the wrong answer here.) To this end, let  $z = e^{i\theta}$  so that

$$\cos \theta = \frac{z + z^{-1}}{2} \text{ and } \sin \theta = \frac{z - z^{-1}}{2i} \text{ and}$$

$$dz = ie^{i\theta}d\theta = izd\theta, \text{ so that } d\theta = \frac{dz}{iz}.$$

We may write the integral as

$$I = \oint_{|z|=1} \frac{\frac{z+z^{-1}}{2}}{5 + 4\frac{z+z^{-1}}{2}} \frac{dz}{iz} = \frac{1}{2i} \oint_{|z|=1} \frac{1}{z} \frac{(z^2 + 1)}{5z + 2z^2 + 2} dz.$$

The integrand has a singular points at  $z = 0$  and

$$z = \frac{-5 \pm (4 - 16)^{1/2}}{4} = \frac{-5 \pm (25 - 16)^{1/2}}{4} = \frac{-5 \pm (9)^{1/2}}{4}$$

$$= \frac{-5 \pm 3}{4} = \left\{ -2, -\frac{1}{2} \right\}.$$

Hence the answer is

$$I = 2\pi i \frac{1}{2i} \left( \text{res}_0 + \text{res}_{-\frac{1}{2}} \right) \left[ \frac{1}{z} \frac{(z^2 + 1)}{5z + 2z^2 + 2} \right] = \pi \left[ \frac{1}{2} + \frac{1 + (-\frac{1}{2})^2}{(-\frac{1}{2})(4(-\frac{1}{2}) + 5)} \right]$$

$$= \pi \left[ \frac{1}{2} + \frac{5/4}{-\frac{3}{2}} \right] = -\frac{\pi}{3}$$

**Example 25.3.** Let  $0 < a < 1$ , we wish to compute

$$I = \int_0^\infty \frac{x^{-a}}{x + 1} dx = \frac{\pi}{\sin a\pi}.$$

In order to do this we are going to consider the contour integral

$$\int_{C_R} \frac{z^{-a}}{z + 1} dz$$

where  $C_R$  is as in Figure 11 below and  $z^{-a} := e^{-al(z)}$  where

$$l(z) = \ln |z| + i\theta \text{ where } z = |z|e^{i\theta} \text{ with } 0 < \theta < 2\pi.$$

Hence we are putting the branch cut along the real axis. By the residue calculus,

$$\int_{C_R} \frac{z^{-a}}{z + 1} dz = 2\pi i \text{res}_{-1} \left[ \frac{z^{-a}}{z + 1} \right] = 2\pi i (-1)^{-a} = 2\pi i (e^{i\pi})^{-a} = 2\pi i e^{-i\pi a}.$$

On the other hand we have, as usual,

$$|z^{-a}| = e^{-a \text{Re} l(z)} = e^{-a \ln |z|} = |z|^{-a}$$

and hence for  $|z| = R$  we have

$$\left| \frac{z^{-a}}{z + 1} \right| \cong \frac{R^{-a}}{1 + R}$$

so that

$$\left| \int_{C_R \cap \{|z|=R\}} \frac{z^{-a}}{z + 1} dz \right| \leq 2\pi R \frac{R^{-a}}{1 + R} \rightarrow 0 \text{ as } R \rightarrow \infty.$$

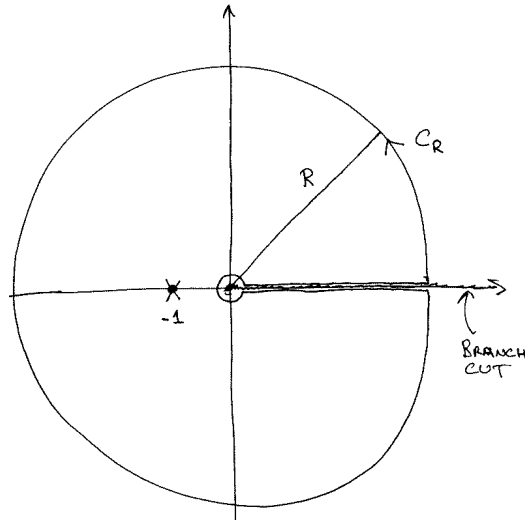

FIGURE 11. A key hole contour.

Therefore we have

$$2\pi i e^{-i\pi a} = \int_{C_R \setminus \{|z|=R\}} \frac{z^{-a}}{z+1} dz = \int_0^R \frac{x^{-a}}{x+1} dx - \int_0^R \frac{x^{-a}}{x+1} dx.$$

Now for  $z = x - i\varepsilon$  just below  $[0, \infty)$  we have  $z^{-a} \cong (xe^{2\pi i})^{-a} = x^{-a}e^{-2\pi ia}$  and hence

$$\begin{aligned} 2\pi i e^{-i\pi a} &= \lim_{R \rightarrow \infty} \left[ \int_0^R \frac{x^{-a}}{x+1} dx - e^{-2\pi ia} \int_0^R \frac{x^{-a}}{x+1} dx \right] \\ &= I(1 - e^{-2\pi ia}). \end{aligned}$$

That is

$$I = \frac{2\pi i e^{-i\pi a}}{1 - e^{-2\pi ia}} = \pi \frac{2i}{e^{i\pi a} - e^{-i\pi a}} = \frac{\pi}{\sin a\pi}.$$

**Lemma 25.4** (Jordan's Lemma).

$$\int_0^\pi e^{-R \sin \theta} d\theta < \frac{\pi}{R}.$$

**Proof.** By symmetry and since  $\sin \theta \leq \frac{2}{\pi}\theta$  for  $\theta \in [0, \pi/2]$ , see Figure 12, we have

$$\int_0^\pi e^{-R \sin \theta} d\theta = 2 \int_0^{\pi/2} e^{-R \sin \theta} d\theta < 2 \int_0^{\pi/2} e^{-R \frac{2}{\pi}\theta} d\theta = -\frac{\pi}{R} e^{-R \frac{2}{\pi}\theta} \Big|_0^{\pi/2} \leq \frac{\pi}{R}.$$

■

**Exercise 25.5.** Show

$$(25.1) \quad \int_{-1}^1 \frac{\sin Mx}{x} dx = \int_{-M}^M \frac{\sin x}{x} dx \rightarrow \pi \text{ as } M \rightarrow \infty$$



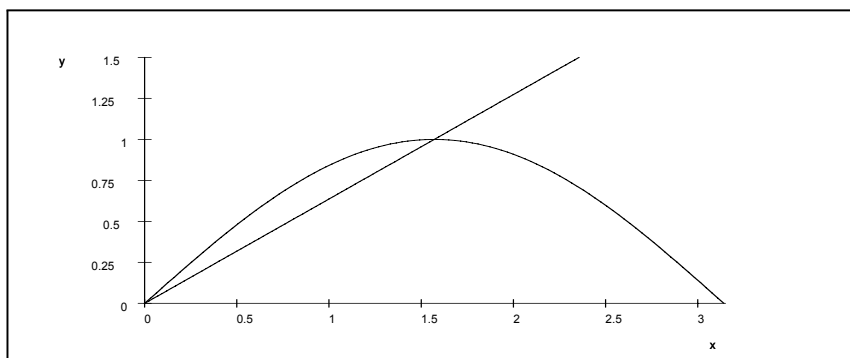

FIGURE 12. Bounding  $\sin \theta$  by a straight line.

using the following method.<sup>2</sup>

- (1) Show that

$$g(z) = \begin{cases} z^{-1} \sin z & \text{for } z \neq 0 \\ 1 & \text{if } z = 0 \end{cases}$$

defines a holomorphic function on  $\mathbb{C}$ .

- (2) Let  $\Gamma_M$  denote the straight line path from  $-M$  to  $-1$  along the real axis followed by the contour  $e^{i\theta}$  for  $\theta$  going from  $\pi$  to  $2\pi$  and then followed by the straight line path from  $1$  to  $M$ . Explain why

$$\int_{-M}^M \frac{\sin x}{x} dx = \int_{\Gamma_M} \frac{\sin z}{z} dz \left( = \frac{1}{2i} \int_{\Gamma_M} \frac{e^{iz}}{z} dz - \frac{1}{2i} \int_{\Gamma_M} \frac{e^{-iz}}{z} dz \right).$$

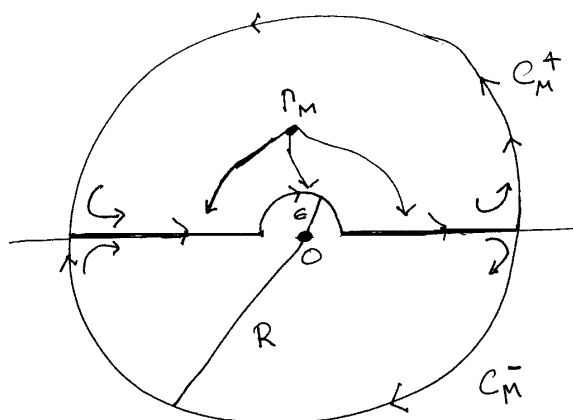

FIGURE 13. The contours used in Exercise 25.5.

<sup>2</sup>In previous notes we evaluated this limit by real variable techniques based on the identity that  $\frac{1}{x} = \int_0^\infty e^{-\lambda x} d\lambda$  for  $x > 0$ .

- (3) Let  $C_M^+$  denote the path  $Me^{i\theta}$  with  $\theta$  going from 0 to  $\pi$  and  $C_M^-$  denote the path  $Me^{i\theta}$  with  $\theta$  going from  $\pi$  to  $2\pi$ . By deforming paths and using the Cauchy integral formula, show

$$\int_{\Gamma_M + C_M^+} \frac{e^{iz}}{z} dz = 2\pi i \text{ and } \int_{\Gamma_M - C_M^-} \frac{e^{-iz}}{z} dz = 0.$$

- (4) Show (by writing out the integrals explicitly) that

$$\lim_{M \rightarrow \infty} \int_{C_M^+} \frac{e^{iz}}{z} dz = 0 = \lim_{M \rightarrow \infty} \int_{C_M^-} \frac{e^{-iz}}{z} dz.$$

26. (12/5/2003) LECTURE 26: COURSE REVIEW

The following two theorems summarize the main theoretical content of Math 120A.

**Theorem 26.1** (Analytic Functions). *Let  $\Omega \subset_o \mathbb{C}$  be an open set and  $f \in C(\Omega, \mathbb{C})$ , then the following statements are equivalent:*

- (1)  $f \in H(\Omega)$ , i.e.  $f$  is analytic in  $\Omega$ .
- (2)  $f(x + iy) = u(x, y) + iv(x, y)$  with  $u$  and  $v$  being continuously differentiable functions satisfying the Cauchy Riemann equations,

$$f_y(x + iy) = if_x(x + iy)$$

or equivalently

$$u_y = -v_x \text{ and } u_x = v_y.$$

- (3)  $\int_{\partial T} f(z)dz = 0$  for all solid triangles  $T \subset \Omega$ .
- (4)  $\int_C f(z) dz = 0$  for any closed contour in  $\Omega$  which is homotopic to a constant loop.
- (5)  $\int_\alpha f(z) dz = \int_\beta f(z) dz$  for any two contours in  $\Omega$  which are homotopic in  $\Omega$  keeping the endpoints fixed.
- (6) For all disks  $D = D(z_0, \rho)$  such that  $\bar{D} \subset \Omega$ ,

$$(26.1) \quad f(z) = \frac{1}{2\pi i} \oint_{\partial D} \frac{f(w)}{w - z} dw \text{ for all } z \in D.$$

- (7) For all disks  $D = D(z_0, \rho)$  such that  $\bar{D} \subset \Omega$ ,  $f(z)$  may be represented as a convergent power series

$$(26.2) \quad f(z) = \sum_{n=0}^{\infty} a_n(z - z_0)^n \text{ for all } z \in D.$$

In particular  $f \in C^\infty(\Omega, \mathbb{C})$ .

Moreover if  $D$  is as above, we have

$$(26.3) \quad f^{(n)}(z) = \frac{n!}{2\pi i} \oint_{\partial D} \frac{f(w)}{(w - z)^{n+1}} dw \text{ for all } z \in D$$

and the coefficients  $a_n$  in Eq. (26.2) are given by

$$(26.4) \quad a_n = \frac{f^{(n)}(z_0)}{n!} = \frac{1}{2\pi i} \oint_{\partial D} \frac{f(w)}{(w - z_0)^{n+1}} dw.$$

We also have if  $A(z_0, r, R) \subset \Omega$  where

$$A(z_0, r, R) := \{z \in \mathbb{C} : r < |z - z_0| < R\},$$

then following **Laurent series** converges absolutely,

$$f(z) = \sum_{n=-\infty}^{\infty} a_n(z - z_0)^n \text{ for all } z \in A(z_0, r, R)$$

where

$$a_n = \frac{1}{2\pi i} \oint_{C_\rho} \frac{f(z)}{(z - z_0)^{n+1}} dz.$$

**Theorem 26.2** (Residue Theorem). *Suppose that  $f : \Omega \setminus \{z_1, \dots, z_n\} \rightarrow \mathbb{C}$  is an analytic function and  $C$  is a simple counter clockwise closed contour in  $\Omega$  such that  $C$  “surrounds”  $\{z_1, \dots, z_n\}$ , then*

$$\int_C f(z) dz = 2\pi i \sum_{i=1}^n \text{res}_{z_i} f.$$

where

$$\text{res}_{z_0} f := \frac{1}{2\pi i} \oint_{|z-z_0|=\varepsilon} f(z) dz = a_{-1}$$

where  $a_{-1}$  is the coefficient of  $(z - z_0)^{-1}$  in the Laurent series expansion of  $f$  near  $z_0$ . The following formula for computing residues is often useful:

$$\text{res}_{z=z_0} \frac{h(z)}{g(z)} := \frac{h(z_0)}{g'(z_0)}$$

provided that  $h$  and  $g$  are analytic near  $z_0$ ,  $g(z_0) = 0$  while  $g'(z_0) \neq 0$ .

### 26.1. Study Guide for Math 120A Final (What you should know).

- (1)  $\mathbb{C} := \{z = x + iy : x, y \in \mathbb{R}\}$  with  $i^2 = -1$  and  $\bar{z} = x - iy$ . The complex numbers behave much like the real numbers. In particular the quadratic formula holds.
- (2)  $|z| = \sqrt{x^2 + y^2} = \sqrt{z\bar{z}}$ ,  $|zw| = |z||w|$ ,  $|z + w| \leq |z| + |w|$ ,  $\text{Re } z = \frac{z + \bar{z}}{2}$ ,  $\text{Im } z = \frac{z - \bar{z}}{2i}$ ,  $|\text{Re } z| \leq |z|$  and  $|\text{Im } z| \leq |z|$ . We also have  $\overline{z\bar{w}} = \bar{z}\bar{w}$  and  $\overline{z + w} = \bar{z} + \bar{w}$  and  $z^{-1} = \frac{\bar{z}}{|z|^2}$ .
- (3)  $\{z : |z - z_0| = \rho\}$  is a circle of radius  $\rho$  centered at  $z_0$ .  
 $\{z : |z - z_0| < \rho\}$  is the open disk of radius  $\rho$  centered at  $z_0$ .  
 $\{z : |z - z_0| \geq \rho\}$  is every thing outside of the open disk of radius  $\rho$  centered at  $z_0$ .
- (4)  $e^z = e^x (\cos y + i \sin y)$ , every  $z = |z| e^{i\theta}$ .
- (5)  $\arg(z) = \{\theta \in \mathbb{R} : z = |z| e^{i\theta}\}$  and  $\text{Arg}(z) = \theta$  if  $-\pi < \theta \leq \pi$  and  $z = |z| e^{i\theta}$ . Notice that  $z = |z| e^{i \arg(z)}$
- (6)  $z^{1/n} = \sqrt[n]{|z|} e^{i \frac{\arg(z)}{n}}$ .
- (7)  $\lim_{z \rightarrow z_0} f(z) = L$ . Usual limit rules hold from real variables.
- (8) Mapping properties of simple complex functions
- (9) The definition of complex differentiable  $f(z)$ . Examples,  $p(z)$ ,  $e^z$ ,  $e^{p(z)}$ ,  $1/z$ ,  $1/p(z)$  etc.
- (10) Key points of  $e^z$  are is  $\frac{d}{dz} e^z = e^z$  and  $e^z e^w = e^{z+w}$ .
- (11) All of the usual derivative formulas hold, in particular product, sum, and chain rules:

$$\frac{d}{dz} f(g(z)) = f'(g(z)) g'(z)$$

and

$$\frac{d}{dt} f(z(t)) = f'(z(t)) \dot{z}(t).$$

- (12)  $\text{Re } z$ ,  $\text{Im } z$ ,  $\bar{z}$ , are nice functions from the real - variables point of view but are **not** complex differentiable.
- (13) Integration:

$$\int_a^b z(t) dt := \int_a^b x(t) dt + i \int_a^b y(t) dt.$$

All of the usual integration rules hold, like the fundamental theorem of calculus, linearity and integration by parts.

- (14) Be able to use the Cauchy Riemann equations to check that a function is analytic and find harmonic conjugates
- (15) You should understand and be able to use the following analytic functions:
- $e^z = e^x (\cos y + i \sin y) = \sum_{n=0}^{\infty} \frac{1}{n!} z^n$ .
  - $\log z = \ln |z| + i \arg z$  and its branches:

$$\text{Log}(1-z) = -\sum_{n=0}^{\infty} \frac{1}{n+1} z^{n+1} \text{ if } |z| < 1.$$

- (c)  $z^\alpha$  and its branches: if  $(1+z)^\alpha = e^{\alpha \text{Log}(1+z)}$  then

$$(1+z)^\alpha = \sum_{n=0}^{\infty} \frac{\alpha(\alpha-1)\dots(\alpha-n+1)}{n!} z^n$$

in particular if  $\alpha = -1$ , then

$$\frac{1}{1-z} = \sum_{n=0}^{\infty} z^n.$$

(d)  $\sin(z) := \frac{e^{iz} - e^{-iz}}{2i} = \sum_{n=0}^{\infty} \frac{(-1)^n}{(2n+1)!} z^{2n+1}$

(e)  $\cos(z) := \frac{e^{iz} + e^{-iz}}{2} = \sum_{n=0}^{\infty} \frac{(-1)^n}{(2n)!} z^{2n}$

(f)  $\sinh(z) := \frac{e^z - e^{-z}}{2} = \sum_{n=0}^{\infty} \frac{1}{(2n+1)!} z^{2n+1}$

(g)  $\cosh(z) := \frac{e^z + e^{-z}}{2} = \sum_{n=0}^{\infty} \frac{1}{(2n)!} z^{2n}$

(h)  $\tan(z) = \frac{\sin(z)}{\cos(z)} = -i \frac{e^{iz} - e^{-iz}}{e^{iz} + e^{-iz}}$

(i)  $\tanh(z) = \frac{\sinh(z)}{\cosh(z)} = \frac{e^z - e^{-z}}{e^z + e^{-z}}$

- (16) Be able to compute contour integrals by parametrizing the contour to get

$$\int_C f(z) dz = \int_a^b f(z(t)) \dot{z}(t) dt.$$

- (17) Be able to estimate contour integrals using

$$\left| \int_C f(z) dz \right| \leq \max_{z \in C} |f(z)| \cdot \text{length}(C).$$

- (18) Be able to compute contour integrals using the fundamental theorem of calculus: if  $f$  is analytic on a neighborhood of a contour  $C$ , then

$$\int_C f'(z) dz = f(C_{\text{end}}) - f(C_{\text{begin}}).$$

- (19) Be able to compute simple Taylor series and Laurent series expansions of a function  $f$  centered at a point  $z_0 \in \mathbb{C}$ . **Hint:** If  $z_0 \neq 0$ , write  $z = z_0 + h$  and then do the expansion in  $h$  about  $h = 0$ . At the end replace  $h$  by  $z - z_0$ .
- (20) Be able to compute residues and use the residue theorem for computing contour integrals.
- (21) Be able to use complex techniques to compute real integrals as have appeared on the homework problems.

## 27. FOR THOSE INTERESTED: THEORY SKIPPED IN LECTURES

**27.1. Differentiating and integrating a sum of analytic functions.** We now restate and prove the differentiating and integrating a sum of analytic functions Theorem 20.1.

**Theorem 27.1** (Differentiating and integrating a sum of analytic functions). *Suppose that  $f_n : \Omega \rightarrow \mathbb{C}$  is a sequence of analytic functions such that*

$$|f_n(z)| \leq M_n \text{ for all } n \in \mathbb{N} \text{ and } z \in \mathbb{C}$$

where  $\sum_{n=1}^{\infty} M_n < \infty$ . Then

(1) If  $C$  is any contour in  $\Omega$ , we have

$$\int_C F(z) dz = \sum_{n=1}^{\infty} \int_C f_n(z) dz.$$

(2) The function  $F(z) := \sum_{n=1}^{\infty} f_n(z)$  is analytic.

(3)  $F'(z) = \sum_{n=1}^{\infty} f'_n(z)$  and in fact

$$(27.1) \quad F^{(k)}(z) = \sum_{n=1}^{\infty} f_n^{(k)}(z) \text{ for all } k \in \mathbb{N}_0 \text{ and } z \in \Omega.$$

Part of the assertion here is that all sums appearing are absolutely convergent.

**Proof.**

(1) Since

$$\sum_{n=1}^{\infty} \left| \int_C f_n(z) dz \right| \leq \sum_{n=1}^{\infty} M_n \ell(C) < \infty$$

where  $\ell(C)$  is the length of  $C$ , the sum  $\sum_{n=1}^{\infty} \int_C f_n(z) dz$  is absolutely convergent. Moreover

$$\left| \int_C F(z) dz - \sum_{n=1}^N \int_C f_n(z) dz \right| = \left| \int_C \left[ F(z) - \sum_{n=1}^N f_n(z) \right] dz \right| \leq \varepsilon_N \ell(C)$$

where

$$\begin{aligned} \varepsilon_N &:= \max_C \left| F(z) - \sum_{n=1}^N f_n(z) \right| \leq \max_C \left| \sum_{n=N+1}^{\infty} f_n(z) \right| \\ &\leq \sum_{n=N+1}^{\infty} M_n \rightarrow 0 \text{ as } N \rightarrow \infty. \end{aligned}$$

(2) Suppose that  $T$  is a solid triangle inside of  $\Omega$ , then by item 1.,

$$\int_{\partial T} F(z) dz = \sum_{n=1}^{\infty} \int_{\partial T} f_n(z) dz = 0$$

where the last equality is a consequence of the Cauchy Goursat Theorem or the converse to Morera's theorem. It now follows by an application of Morera's theorem that  $F$  is analytic on  $\Omega$ . (Item 2. will also be proved in the course of the proof of item 3.)

- (3) Since complex differentiability is a local assertion, let us fix  $z_0 \in \Omega$  and  $\rho > 0$  such that  $\overline{D(z_0, \rho)} \subset \Omega$  and let  $r = \text{dist}(z_0, \partial\Omega) > \rho$ . Then by the Cauchy estimate in Corollary 18.7 with  $n = 1$ , we learn

$$|f'_n(z)| \leq \frac{1}{r - \rho} M_n \text{ for all } z \in D(z_0, \rho).$$

We now suppose  $z \in D(z_0, \rho)$  and  $h \in \mathbb{C} \setminus \{0\}$  with  $|h| < \rho - |z|$ . Using the definition of the derivative and properties of the sum,

$$\frac{F(z+h) - F(z)}{h} - \sum_{n=1}^{\infty} f'_n(z) = \sum_{n=1}^{\infty} \left[ \frac{f_n(z+h) - f_n(z)}{h} - f'_n(z) \right].$$

By the fundamental theorem of calculus and the chain rule,

$$f_n(z+h) - f_n(z) = \int_0^1 \frac{d}{dt} f_n(z+th) dt = h \int_0^1 f'_n(z+th) dt$$

which implies

$$\begin{aligned} \left| \frac{f_n(z+h) - f_n(z)}{h} - f'_n(z) \right| &= \left| \int_0^1 [f'_n(z+th) - f'_n(z)] dt \right| \\ &\leq \int_0^1 |f'_n(z+th) - f'_n(z)| dt \leq \frac{2}{r - \rho} M_n. \end{aligned}$$

Therefore for any  $N \in \mathbb{N}$  we have

$$\begin{aligned} \left| \frac{F(z+h) - F(z)}{h} - \sum_{n=1}^{\infty} f'_n(z) \right| &\leq \sum_{n=1}^{\infty} \left| \frac{f_n(z+h) - f_n(z)}{h} - f'_n(z) \right| \\ &\leq \sum_{n=1}^N \left| \frac{f_n(z+h) - f_n(z)}{h} - f'_n(z) \right| + \frac{2}{\rho} \sum_{n=N+1}^{\infty} M_n. \end{aligned}$$

So letting  $h \rightarrow 0$  in this expression shows

$$\lim_{h \rightarrow 0} \left| \frac{F(z+h) - F(z)}{h} - \sum_{n=1}^{\infty} f'_n(z) \right| \leq \frac{2}{\rho} \sum_{n=N+1}^{\infty} M_n \rightarrow 0 \text{ and } N \rightarrow \infty.$$

This procedure may be repeated to prove Eq. (27.1). Since  $z_0 \in \Omega$  was arbitrary, the proof is complete.

■

### 27.2. The Basic Theory of Power Series.

**Lemma 27.2** (Root and Ratio Test). *Suppose  $\{z_n\}_{n=0}^{\infty} \subset \mathbb{C}$  and*

$$\rho := \lim_{n \rightarrow \infty} \sqrt[n]{|z_n|} \text{ or } \rho := \lim_{n \rightarrow \infty} \left| \frac{z_{n+1}}{z_n} \right| \text{ exists}$$

then

- (1) If  $\rho < 1$  then  $\sum_{n=0}^{\infty} |z_n| < \infty$  and hence  $\sum_{n=0}^{\infty} z_n$  is convergent.
- (2) If  $\rho > 1$ ,  $\lim_{n \rightarrow \infty} |z_n| = \infty$  and  $\sum_{n=0}^{\infty} z_n$  is divergent.
- (3) If  $\rho = 1$ , the test fails and you have to **work harder**.

**Proof.**

- (1) Suppose  $\rho < 1$  and let  $\rho < r < 1$ .

- (a) Suppose first that  $\rho := \lim_{n \rightarrow \infty} \sqrt[n]{|z_n|}$ , then  $\sqrt[n]{|z_n|} \leq r$  for large  $n$  and hence

$$|z_n| \leq r^n \text{ for large } n, \text{ say } n \geq N.$$

Since  $\sum_N^\infty |z_n| \leq \sum_N^\infty r^n \leq \frac{1}{1-r} < \infty$ , the sum is absolutely convergent.

- (b) Suppose now that  $\rho := \lim_{n \rightarrow \infty} \left| \frac{z_{n+1}}{z_n} \right|$ . Then again for  $n \geq N$  for some  $N$  we have

$$\left| \frac{z_{n+1}}{z_n} \right| \leq r \text{ i.e. } |z_{n+1}| \leq r |z_n| \text{ for all } n \geq N.$$

This then implies

$$|z_{N+n}| \leq r |z_{N+n-1}| \leq r^2 |z_{N+n-2}| \leq \cdots \leq r^n |z_N|.$$

So again

$$\sum_N^\infty |z_n| \leq |z_N| \sum_N^\infty r^n \leq |z_N| \frac{1}{1-r} < \infty$$

and the original sum is absolutely convergent.

- (2) Suppose  $\rho > 1$  and let  $\rho > r > 1$ .

- (a) Suppose first that  $\rho := \lim_{n \rightarrow \infty} \sqrt[n]{|z_n|}$ , then  $\sqrt[n]{|z_n|} \geq r$  for large  $n$  and hence

$$|z_n| \geq r^n \text{ for large } n$$

and hence  $\lim_{n \rightarrow \infty} |z_n| = \infty$  and the series must diverge.

- (b) Suppose now that  $\rho := \lim_{n \rightarrow \infty} \left| \frac{z_{n+1}}{z_n} \right|$ . Then again for  $n \geq N$  for some  $N$  we have

$$\left| \frac{z_{n+1}}{z_n} \right| \geq r \text{ i.e. } |z_{n+1}| \geq r |z_n| \text{ for all } n \geq N.$$

This then implies

$$|z_{N+n}| \geq r |z_{N+n-1}| \geq r^2 |z_{N+n-2}| \geq \cdots \geq r^n |z_N|.$$

So again  $\lim_{n \rightarrow \infty} |z_n| = \infty$  and the series diverge.

■

**Definition 27.3.** Given  $z_0 \in \mathbb{C}$  and  $\{a_n\}_{n=0}^\infty \subset \mathbb{C}$ , the series of the form

$$\sum_{n=0}^{\infty} a_n (z - z_0)^n$$

is called a **power series**. If  $z_0 = 0$  we call it a **Maclaurin series**, i.e. a series of the form

$$\sum_{n=0}^{\infty} a_n z^n.$$

To each power series,  $\sum_{n=0}^{\infty} a_n (z - z_0)^n$ , let

$$r := \sup \left\{ |z - z_0| : z \in \mathbb{C} \text{ and } \sum_{n=0}^{\infty} a_n (z - z_0)^n \text{ exists} \right\}.$$

The number  $r \geq 0$  is called the **radius of convergence of the series**.



**Proposition 27.4.** *If  $r$  is the radius of convergence of a power series*

$$(27.2) \quad \sum_{n=0}^{\infty} a_n (z - z_0)^n$$

then:

- (1) *If  $|z - z_0| < r$ , the series converges.*
- (2) *If  $|z - z_0| > r$ , the series diverges.*
- (3) *If*

$$\mu = \lim_{n \rightarrow \infty} \sqrt[n]{|a_n|} \text{ or } \mu = \lim_{n \rightarrow \infty} \left| \frac{a_{n+1}}{a_n} \right| \text{ exist}$$

$$\text{then } r = \frac{1}{\mu}.$$

**Proof.** For simplicity of exposition we will assume that  $z_0 = 0$ .

- (1) If  $w \in \mathbb{C} \setminus \{0\}$  is a point such that  $\sum_{n=0}^{\infty} a_n w^n$  exists then, with  $\lambda = |w|$ ,

$$\lim_{n \rightarrow \infty} |a_n w^n| = \lim_{n \rightarrow \infty} |a_n| \lambda^n = 0.$$

In particular for large  $n$  we have  $|a_n| \lambda^n \leq 1$  or  $|a_n| \leq \lambda^{-n}$ . Hence if  $|z| < \lambda$ , then

$$|a_n z^n| \leq \left( \frac{|z|}{\lambda} \right)^n$$

for large  $n$  and hence  $\sum_{n=0}^{\infty} |a_n z^n| < \infty$  by comparison with a geometric series. This proves item 1.

- (2) If  $|w| > r$  and  $\sum_{n=0}^{\infty} a_n w^n$  were to exist, this would violate the definition of  $r$ .
- (3) If we apply the root test or the ratio test to the series in Eq. (27.2) we would learn

$$\rho := \lim_{n \rightarrow \infty} \sqrt[n]{|a_n (z - z_0)^n|} = \mu |z - z_0| \text{ or}$$

$$\rho := \lim_{n \rightarrow \infty} \frac{|a_{n+1} (z - z_0)^{n+1}|}{|a_n (z - z_0)^n|} = \mu |z - z_0|$$

and in either case we would learn that the series in Eq. (27.2) converges if  $\rho < 1$  and diverges if  $\rho > 1$  and these later conditions are equivalent to

$$|z - z_0| < \frac{1}{\mu} \text{ and } |z - z_0| > \frac{1}{\mu}.$$

It follows from this that  $r = \frac{1}{\mu}$  in this case.

■

Using these results and our differentiation Theorem 20.1 we get the following corollary.

**Theorem 27.5** (Power Series Integration and Differentiation). *Suppose that*

$$S(z) := \sum_{n=0}^{\infty} a_n (z - z_0)^n \text{ for } z \in D := D(z_0, r)$$

where  $r$  is the radius of convergence of the series which is assumed to be positive. Then:

(1)  $S$  is analytic on  $D$  and

$$(27.3) \quad a_n = \frac{1}{n!} S^{(n)}(z_0) \text{ for all } n \in \mathbb{N}_0.$$

(2) The derivative  $S$  is given by

$$(27.4) \quad S'(z) = \sum_{n=1}^{\infty} n a_n (z - z_0)^{n-1}.$$

and more generally,

$$S^{(k)}(z) = \sum_{n=0}^{\infty} n(n-1)\dots(n-k+1)a_n (z - z_0)^{n-k} \text{ for all } z \in D(z_0, r).$$

(3) If  $C$  is a contour in  $D$  then

$$(27.5) \quad \int_C S(z) dz = \sum_{n=0}^{\infty} a_n \int_C (z - z_0)^n dz = \sum_{n=0}^{\infty} \frac{a_n}{n+1} [(z_f - z_0)^{n+1} - (z_i - z_0)^{n+1}]$$

where  $z_i$  and  $z_f$  are the initial and final points of  $C$  respectively. In particular if  $z_i = z_0$ , then

$$\int_{[z_0, w]} S(z) dz = \sum_{n=0}^{\infty} \frac{a_n}{n+1} (w - z_0)^{n+1}.$$

**Proof.** This all follows from Theorem 20.1 and our discussions about power series in Proposition 27.4 and its proof. ■

**Corollary 27.6** (Removable singularities). *Let  $\Omega \subset_o \mathbb{C}$ ,  $z_0 \in \Omega$  and  $f \in H(\Omega \setminus \{z_0\})$ . If  $\limsup_{z \rightarrow z_0} |f(z)| < \infty$ , i.e.  $\sup_{0 < |z - z_0| < \epsilon} |f(z)| < \infty$  for some  $\epsilon > 0$ , then*

*$\lim_{z \rightarrow z_0} f(z)$  exists. Moreover if we extend  $f$  to  $\Omega$  by setting  $f(z_0) = \lim_{z \rightarrow z_0} f(z)$ , then  $f \in H(\Omega)$ .*

**Proof.** Set

$$g(z) = \begin{cases} (z - z_0)^2 f(z) & \text{for } z \in \Omega \setminus \{z_0\} \\ 0 & \text{for } z = z_0 \end{cases}.$$

Then  $g'(z_0)$  exists and is equal to zero. Therefore  $g'(z)$  exists for all  $z \in \Omega$  and hence  $g \in H(\Omega)$ . We may now expand  $g$  into a power series using  $g(z_0) = g'(z_0) = 0$  to learn  $g(z) = \sum_{n=2}^{\infty} a_n (z - z_0)^n$  which implies

$$f(z) = \frac{g(z)}{(z - z_0)^2} = \sum_{n=0}^{\infty} a_n (z - z_0)^{n-2} \text{ for } 0 < |z - z_0| < \epsilon$$

Therefore,  $\lim_{z \rightarrow z_0} f(z) = a_2$  exists. Defining  $f(z_0) = a_2$  we have  $f(z) = \sum_{n=0}^{\infty} a_n (z - z_0)^{n-2}$  for  $z$  near  $z_0$ . This shows that  $f$  is holomorphic in a neighborhood of  $z_0$  and since  $f$  was already holomorphic away from  $z_0$ ,  $f \in H(\Omega)$ . ■

**Definition 27.7.** We say that  $\Omega$  is a **region** if  $\Omega$  is a connected open subset of  $\mathbb{C}$ .

**Corollary 27.8** (Analytic Continuation). *Let  $\Omega$  be a region and  $f \in H(\Omega)$  and  $Z(f) = f^{-1}(\{0\})$  denote the zero set of  $f$ . Then either  $f \equiv 0$  or  $Z(f)$  has no accumulation points in  $\Omega$ . More generally if  $f, g \in H(\Omega)$  and the set  $\{z \in \Omega : f(z) = g(z)\}$  has an accumulation point in  $\Omega$ , then  $f \equiv g$ .*

**Proof.** The second statement follows from the first by considering the function  $f - g$ . For the proof of the first assertion we will work strictly in  $\Omega$  with the relative topology.

Let  $A$  denote the set of accumulation points of  $Z(f)$  (in  $\Omega$ ). By continuity of  $f$ ,  $A \subset Z(f)$  and  $A$  is a closed<sup>3</sup> subset of  $\Omega$  with the relative topology. The proof is finished by showing that  $A$  is open and thus  $A = \emptyset$  or  $A = \Omega$  because  $\Omega$  is connected.

Suppose that  $z_0 \in A$ , and express  $f(z)$  as its power series expansion

$$f(z) = \sum_{n=0}^{\infty} a_n(z - z_0)^n$$

for  $z$  near  $z_0$ . Since  $0 = f(z_0)$  it follows that  $a_0 = 0$ . Let  $z_k \in Z(f) \setminus \{z_0\}$  such that  $\lim z_k = z_0$ . Then

$$0 = \frac{f(z_k)}{z_k - z_0} = \sum_{n=1}^{\infty} a_n(z_k - z_0)^{n-1} \rightarrow a_1 \text{ as } k \rightarrow \infty$$

so that  $f(z) = \sum_{n=2}^{\infty} a_n(z - z_0)^n$ . Similarly

$$0 = \frac{f(z_k)}{(z_k - z_0)^2} = \sum_{n=2}^{\infty} a_n(z_k - z_0)^{n-2} \rightarrow a_2 \text{ as } k \rightarrow \infty$$

and continuing by induction, it follows that  $a_n \equiv 0$ , i.e.  $f$  is zero in a neighborhood of  $z_0$ . ■

**Definition 27.9.** For  $z \in \mathbb{C}$ , let

$$\cos(z) = \frac{e^{iz} + e^{-iz}}{2} \text{ and } \sin(z) = \frac{e^{iz} - e^{-iz}}{2i}.$$

**Exercise 27.10.** Show the these formula are consistent with the usual definition of  $\cos$  and  $\sin$  when  $z$  is real. Also shows that the addition formula in Exercise 31.15 are valid for  $\theta, \alpha \in \mathbb{C}$ . This can be done with no additional computations by making use of Corollary 27.8.

**Exercise 27.11.** Let

$$f(z) := \frac{1}{\sqrt{2\pi}} \int_{\mathbb{R}} \exp(-\frac{1}{2}x^2 + zx) dm(x) \text{ for } z \in \mathbb{C}.$$

Show  $f(z) = \exp(\frac{1}{2}z^2)$  using the following outline:

- (1) Show  $f \in H(\Omega)$ .
- (2) Show  $f(z) = \exp(\frac{1}{2}z^2)$  for  $z \in \mathbb{R}$  by completing the squares and using the translation invariance of  $m$ . Also recall that you have proved in the first quarter that  $f(0) = 1$ .
- (3) Conclude  $f(z) = \exp(\frac{1}{2}z^2)$  for all  $z \in \mathbb{C}$  using Corollary 27.8.

---

<sup>3</sup>Recall that  $x \in A$  iff  $V'_x \cap Z \neq \emptyset$  for all  $x \in V_x \subset_o \mathbb{C}$  where  $V'_x := V_x \setminus \{x\}$ . Hence  $x \notin A$  iff there exists  $x \in V_x \subset_o \mathbb{C}$  such that  $V'_x \cap Z = \emptyset$ . Since  $V'_x$  is open, it follows that  $V'_x \subset A^c$  and thus  $V_x \subset A^c$ . So  $A^c$  is open, i.e.  $A$  is closed.

**27.3. Partial Fractions.** Consider writing  $\frac{q(z)}{p(z)}$  in partial fraction form. Here we assume  $\deg q < \deg p$ , for otherwise we would divide to make it so. Now fact  $p(z) = \prod_{i=1}^n (z - z_i)^{k_i}$  we wish to write

$$\frac{q(z)}{\prod_{i=1}^n (z - z_i)^{k_i}} = \sum_{i=1}^n \sum_{j=1}^{k_i} a_{ij} \frac{1}{(z - z_i)^{k_i - j + 1}}.$$

Multiplying this equation through by  $p(z)$  shows we must solve

$$q(z) = \sum_{i=1}^n \sum_{j=1}^{k_i} a_{ij} (z - z_i)^{j-1} \prod_{l \neq i} (z - z_l)^{k_l}.$$

Noting that  $k := \deg p = \sum k_i$ , the question comes down to whether the functions

$$\beta := \left\{ p_{ij}(z) := (z - z_i)^{j-1} \prod_{l \neq i} (z - z_l)^{k_l} : i = 1, \dots, n \text{ and } j = 1, \dots, k_i \right\}$$

form a basis for the polynomials of degree  $k - 1$ . This space has dimension  $k$  and there are  $k$  elements in  $\beta$ . So to finish the proof, we need only show that  $\beta$  is a linearly independent set. Suppose that

$$(27.6) \quad F(z) := \sum_{i=1}^n \sum_{j=1}^{k_i} a_{ij} p_{ij}(z) = 0.$$

Evaluating this expression at  $z_1$  shows

$$0 = \sum_{i=1}^n \sum_{j=1}^{k_i} a_{ij} p_{ij}(z_1) = a_{11} \prod_{l \neq 1} (z_1 - z_l)^{k_l}$$

which implies  $a_{11} = 0$ . Similarly by evaluating at  $z_i$  we learn that  $a_{i1} = 0$  for all  $i$  and we are done if  $k_i = 1$  for all  $i$ . So we are left to consider

$$0 = \sum_{i=1}^n \sum_{j \geq 2} a_{ij} p_{ij}(z).$$

This expression will have a common factor of  $\prod_{i: k_i > 1} (z - z_i)$  which when factored out, leaves us to consider

$$0 = \sum_{i=1}^n \sum_{j \geq 2} a_{ij} \tilde{p}_{ij}(z)$$

where

$$\tilde{p}_{ij}(z) = \frac{p_{ij}(z)}{\prod_{i: k_i > 1} (z - z_i)}.$$

In this way we have reduced the maximum  $k_i$  appearing by 1. Hence we may complete the proof by induction on  $\max \{k_i : i = 1, \dots, n\}$ .

**Example 27.12.** Suppose  $p(z) = (z - z_1)(z - z_2)^2(z - z_3)^3$  where now  $K := \max \{k_i : i = 1, 2, 3\} = 3$ . Then we are considering

$$\begin{aligned} 0 &= A(z - z_2)^2(z - z_3)^3 + B(z - z_1)(z - z_2)(z - z_3)^3 \\ &\quad + C(z - z_1)(z - z_3)^3 + D(z - z_1)(z - z_2)^2(z - z_3)^2 \\ &\quad + E(z - z_1)(z - z_2)^2(z - z_3) + F(z - z_1)(z - z_2)^2. \end{aligned}$$

Evaluating at  $z = z_1$  implies,  $A = 0$  and  $z = z_2$  that  $C = 0$  and at  $z = z_3$  that  $F = 0$ . So we are left to consider

$$0 = B(z - z_1)(z - z_2)(z - z_3)^3 + D(z - z_1)(z - z_2)^2(z - z_3)^2 \\ + E(z - z_1)(z - z_2)^2(z - z_3)$$

from which we can factor out  $(z - z_1)(z - z_2)(z - z_3)$  to find

$$0 = B(z - z_3)^2 + D(z - z_2)(z - z_3) + E(z - z_2)$$

and now  $K := \max\{k_i : i = 1, 2, 3\} = 2$ . Evaluating this at  $z = z_1$  and  $z = z_2$  implies that  $E = D = 0$ , so that

$$0 = B(z - z_3)^2$$

and we may factor out  $(z - z_3)$  to get

$$0 = B(z - z_3).$$

Evaluating this at any point other than  $z_3$  implies  $B = 0$ .